

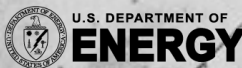

# CALORIMETRY FOR THE ePIC EXPERIMENT

HENRY KLEST

Argonne National Laboratory



Argonne National Laboratory is a  
U.S. Department of Energy laboratory  
managed by UCChicago Argonne, LLC.

# EPIC AT THE EIC

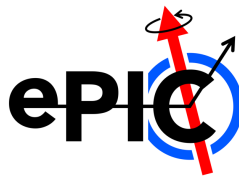

- EIC is a high luminosity machine, enabling precise measurements (Shujie's talk)
  - Much of the EIC physics lives in percent-level effects
  - Requires precision in:

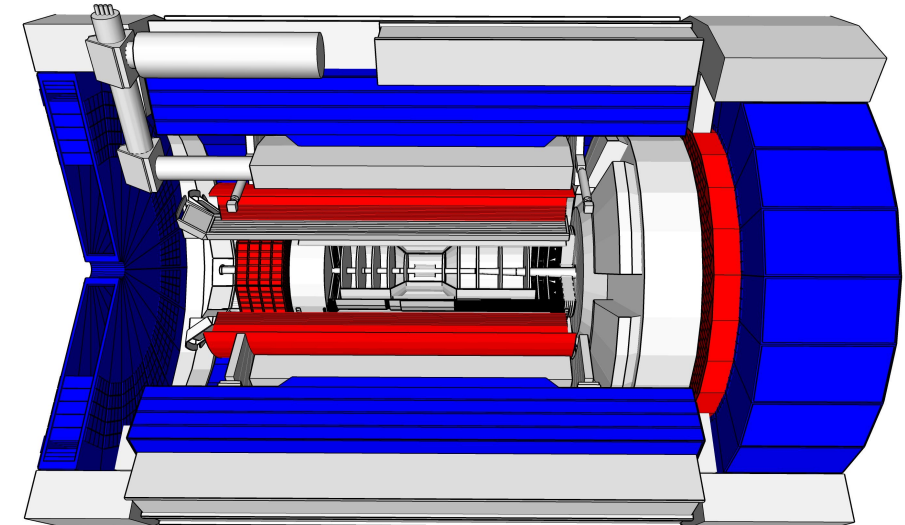
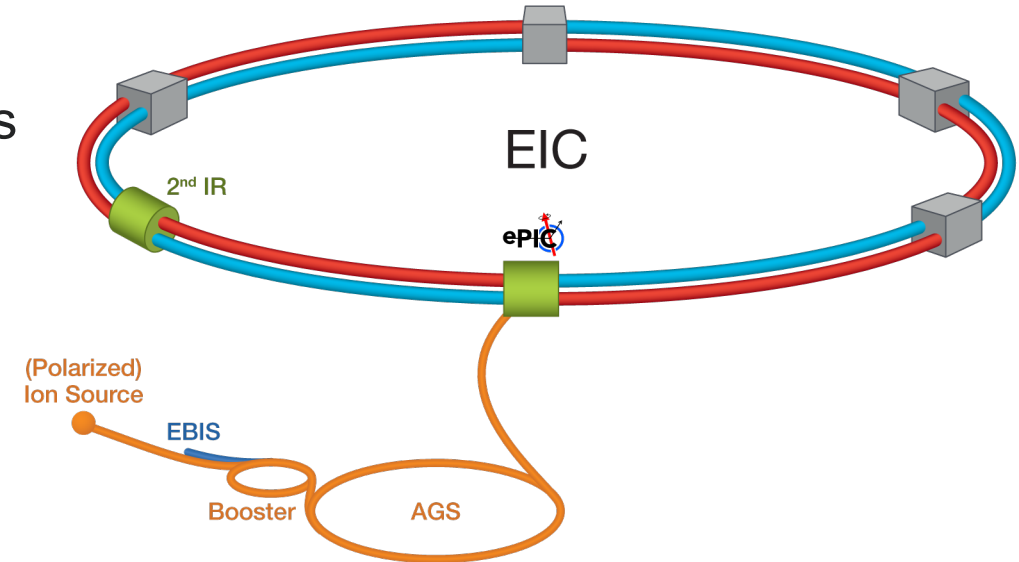

# EPIC AT THE EIC

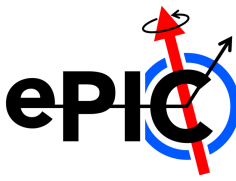

- EIC is a high luminosity machine, enabling precise measurements (Shujie's talk)
  - Much of the EIC physics lives in percent-level effects
  - Requires precision in:
- Particle ID: Chandra's talk

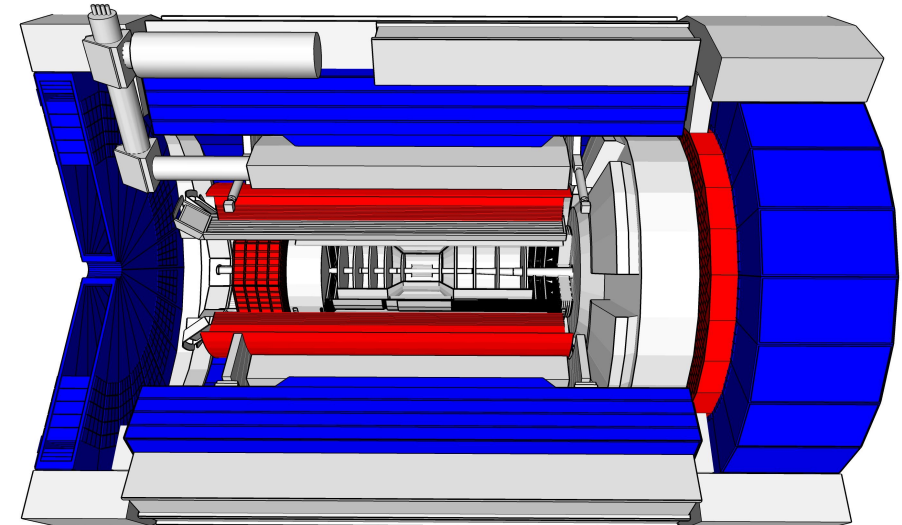
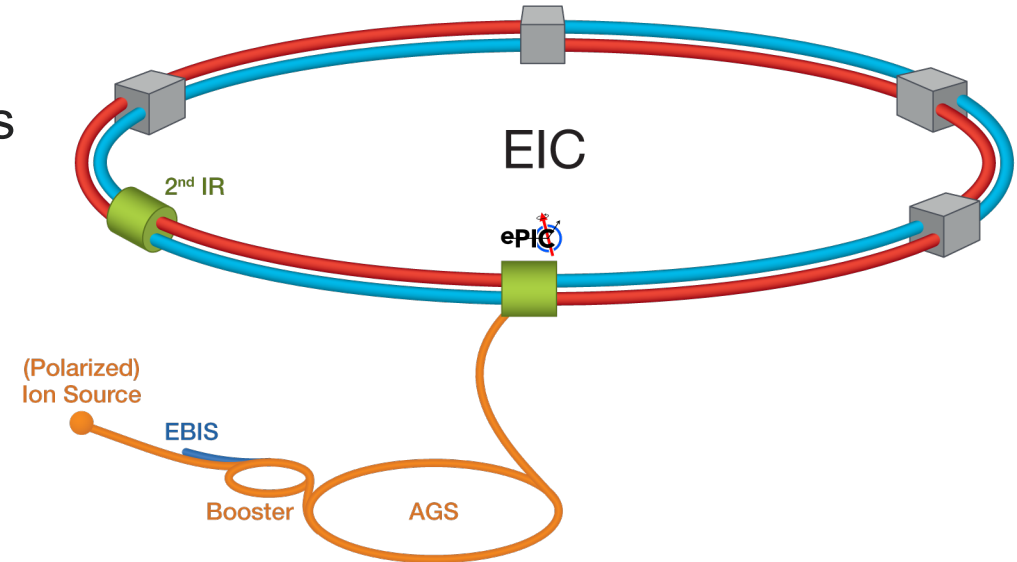

# EPIC AT THE EIC

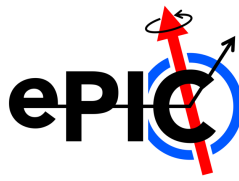

- EIC is a high luminosity machine, enabling precise measurements (Shujie's talk)
  - Much of the EIC physics lives in percent-level effects
  - Requires precision in:
- Particle ID: Chandra's talk
- Tracking & Vertexing: Gian Michele's talk

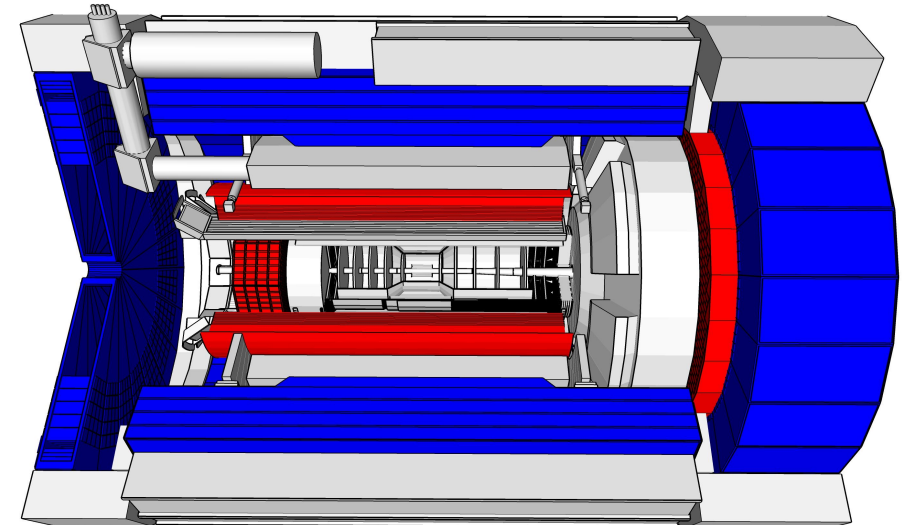
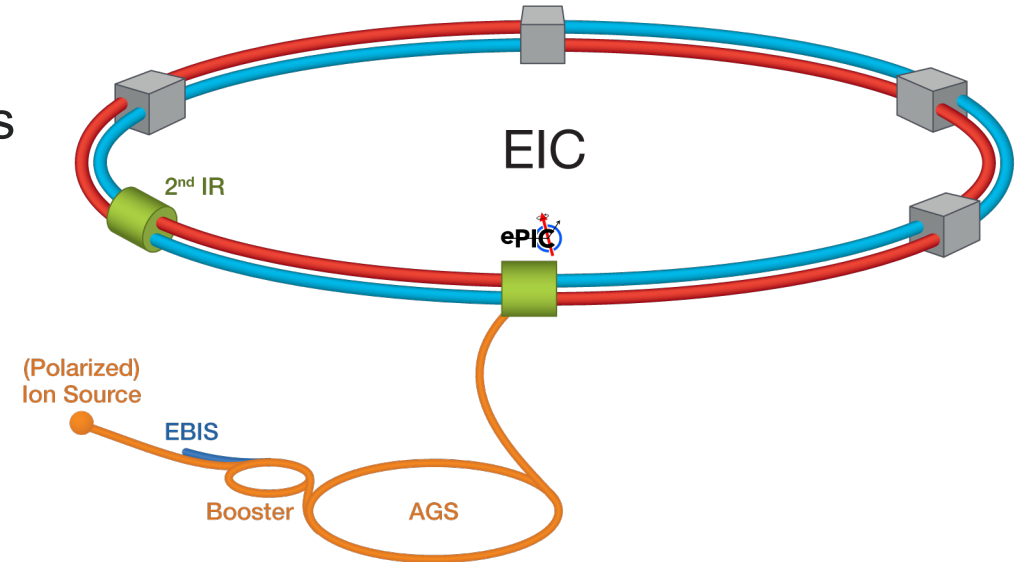



# EPIC AT THE EIC

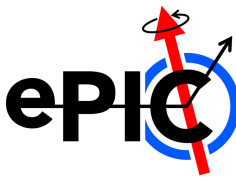

- EIC is a high luminosity machine, enabling precise measurements (Shujie's talk)
  - Much of the EIC physics lives in percent-level effects
  - Requires precision in:
- Particle ID: Chandra's talk
- Tracking & Vertexing: Gian Michele's talk
- Far-forward detectors: Michael's talk

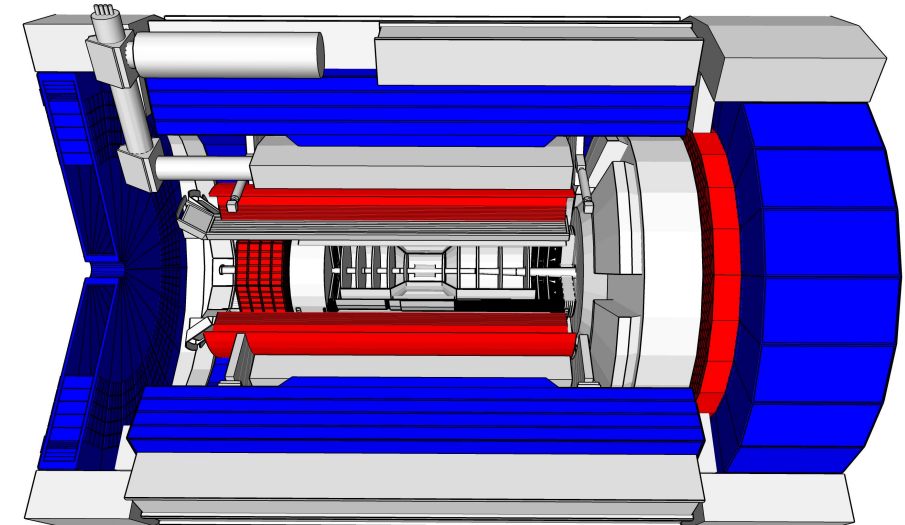
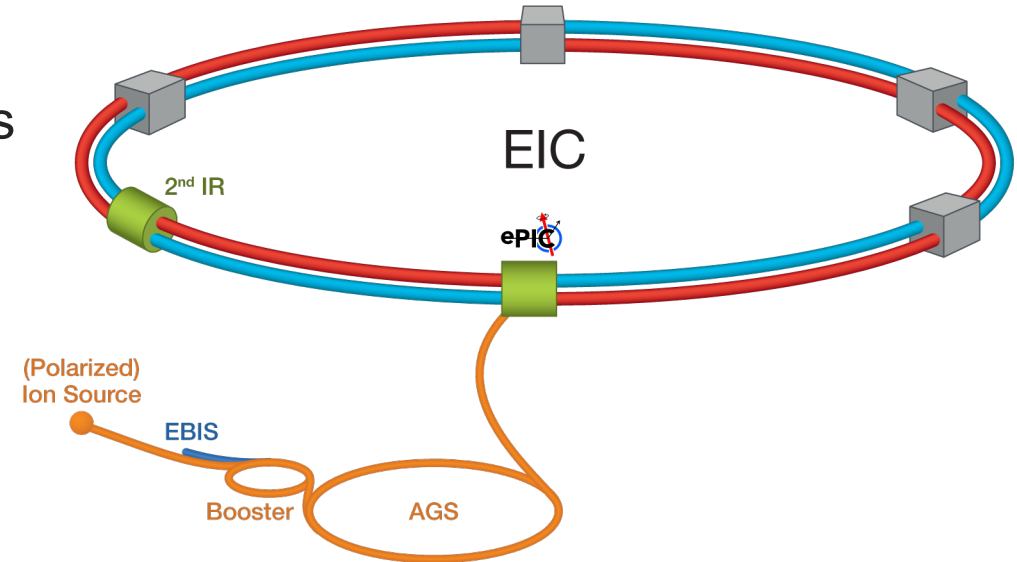

# EPIC AT THE EIC

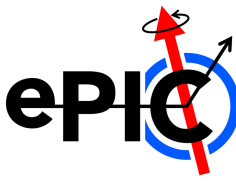

- EIC is a high luminosity machine, enabling precise measurements (Shujie's talk)
  - Much of the EIC physics lives in percent-level effects
  - Requires precision in:
- Particle ID: Chandra's talk
- Tracking & Vertexing: Gian Michele's talk
- Far-forward detectors: Michael's talk
- Calorimetry: this talk

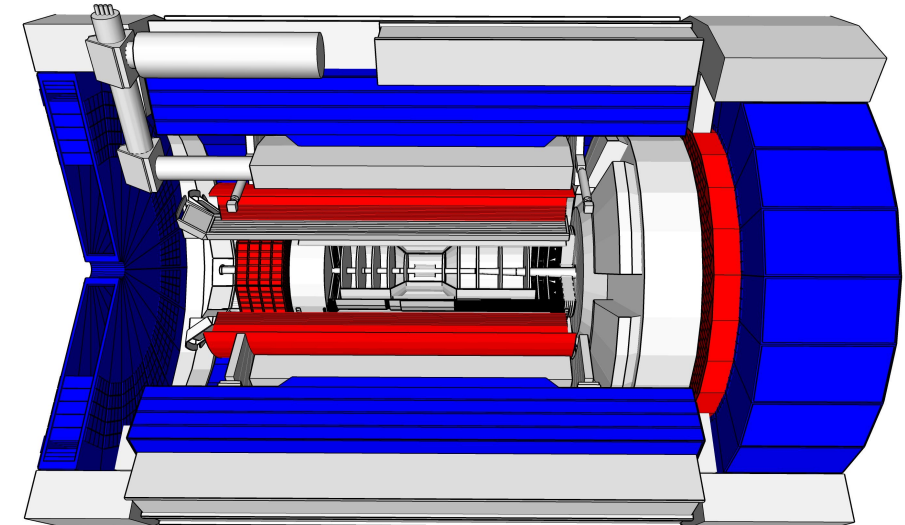
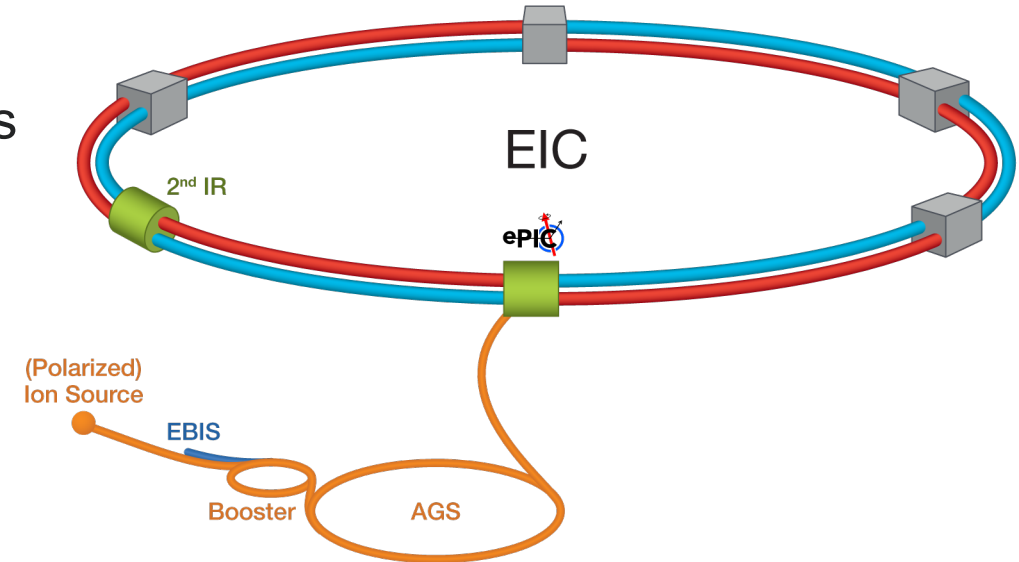

# EPIC AT THE EIC

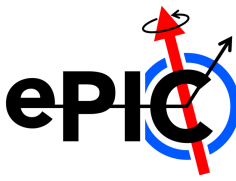

- EIC is a high luminosity machine, enabling precise measurements (Shujie's talk)
  - Much of the EIC physics lives in percent-level effects
  - Requires precision in:
- Particle ID: Chandra's talk
- Tracking & Vertexing: Gian Michele's talk
- Far-forward detectors: Michael's talk
- Calorimetry: this talk
- Cross-check! – Pawel's talk

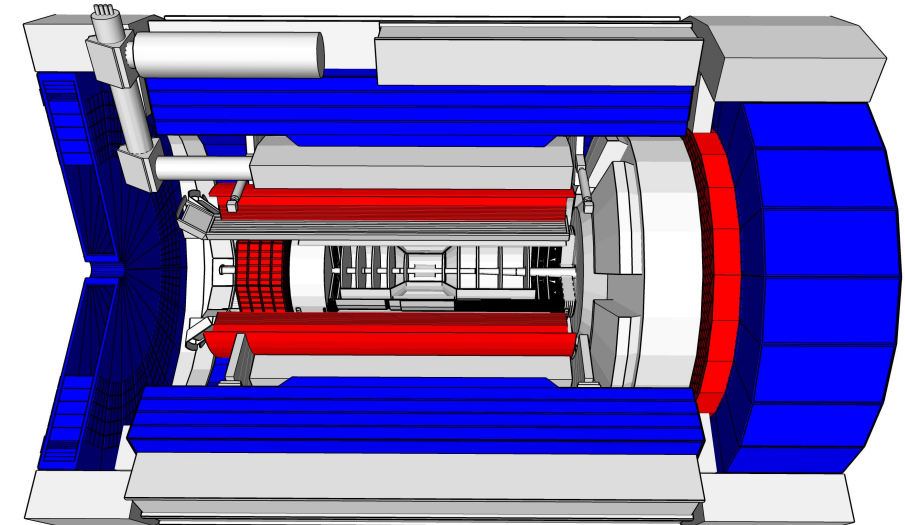
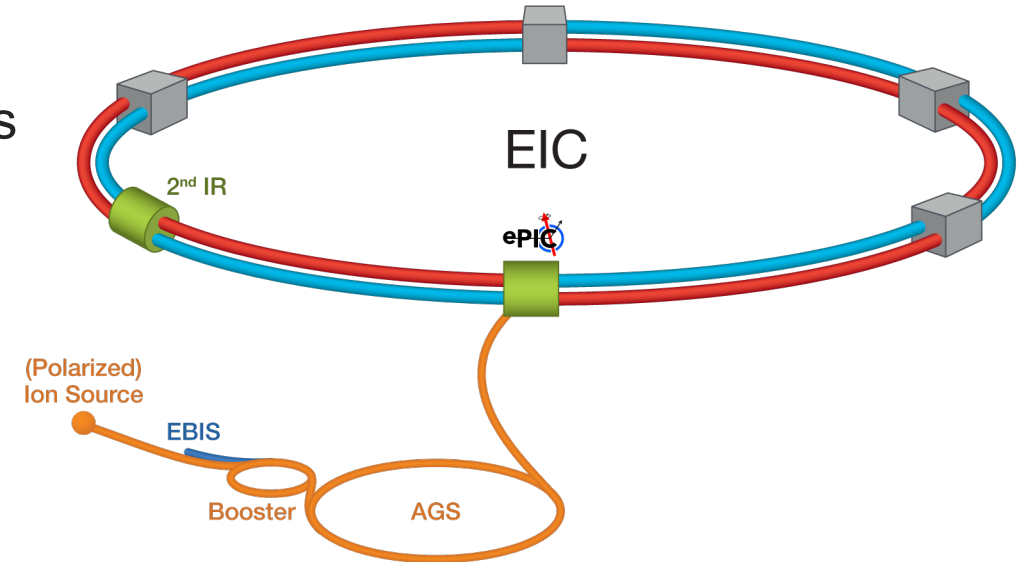

# CALORIMETRY AT THE EIC

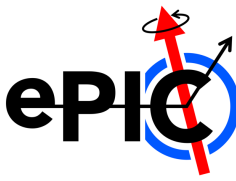

- Calorimetry at the EIC has some unique challenges:
  - Wide variety in CM energy, 5 GeV  $e^-$  x 41 GeV p/A to 18 GeV  $e^-$  x 275 GeV p
- EIC physics lives at all scales!
  - Large dynamic range required, hundreds of GeV to tens of MeV
  - Most challenging constraint is not always simply measuring energy
- Electron identification
  - Very stringent requirements on e/h separation to identify DIS events from the much larger photoproduction background
  - 1-in-10000 rejection of pions in the few GeV range!
- Streaming readout
- Integration with PID & tracking detectors

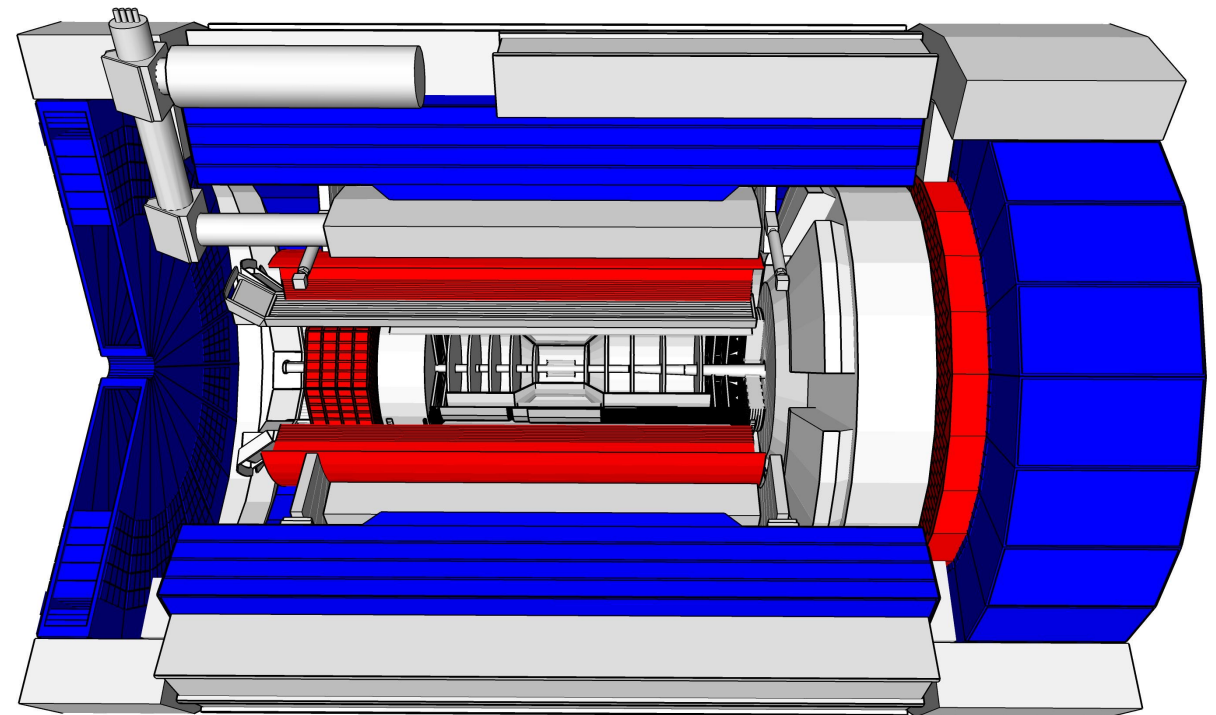

# CALORIMETRY AT THE EIC

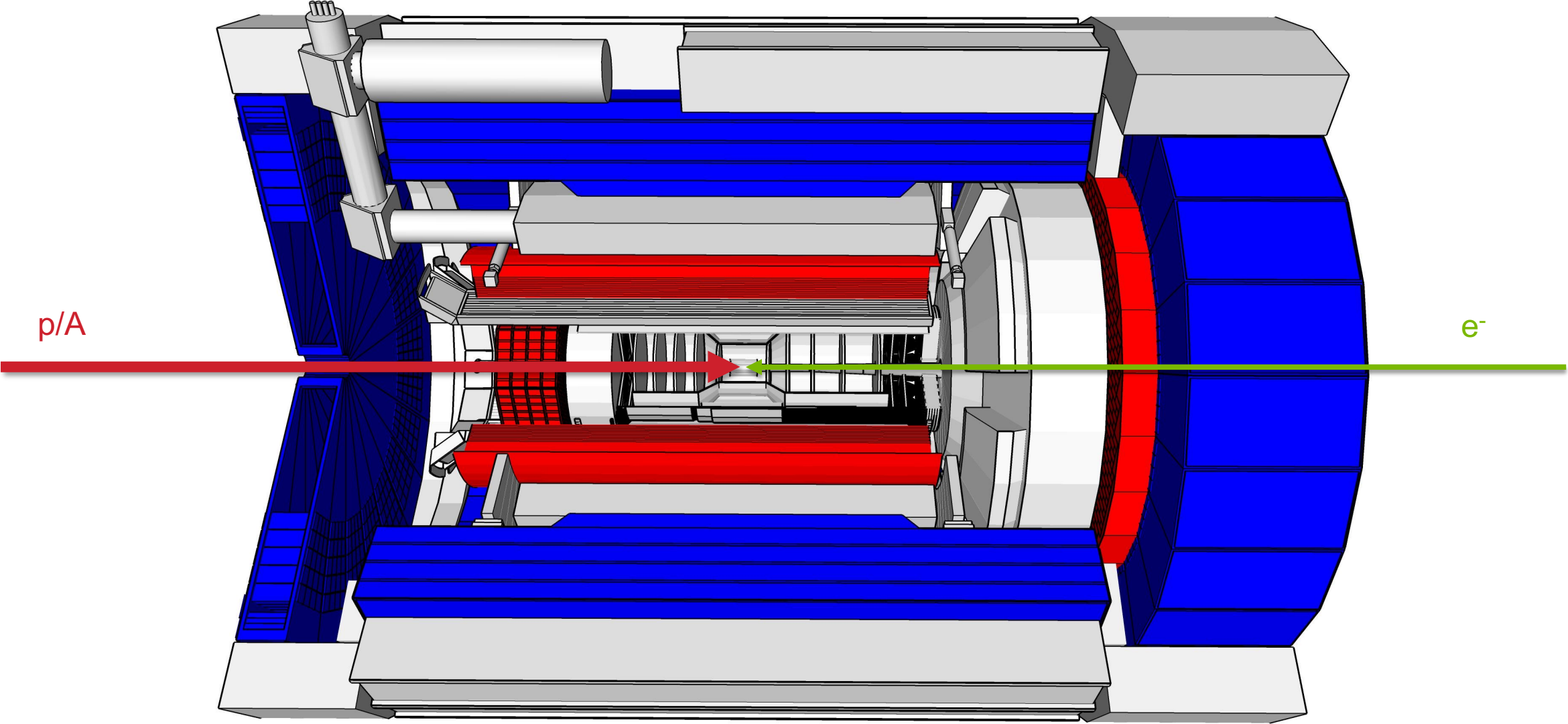



# CALORIMETRY AT THE EIC

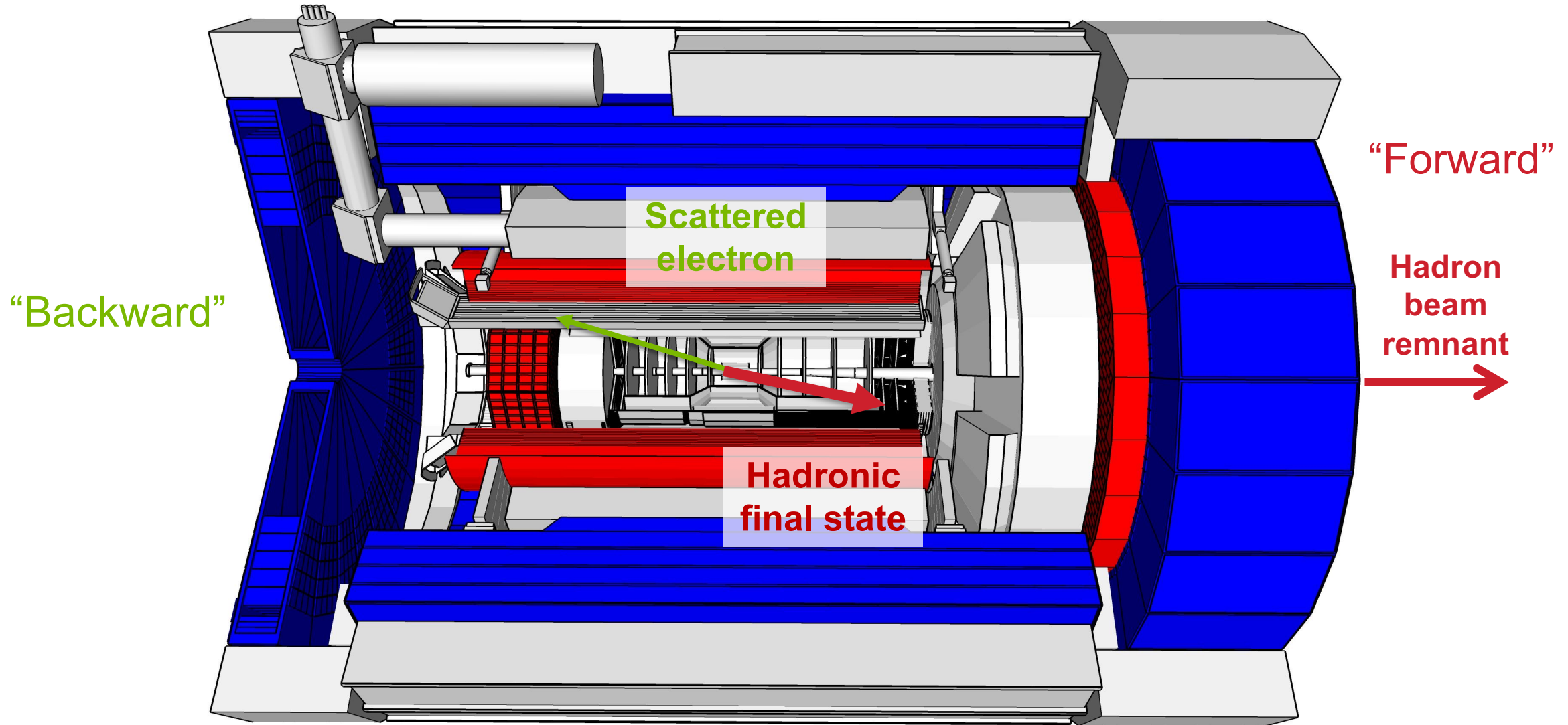
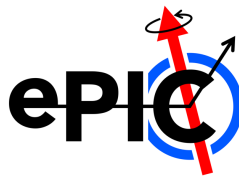

# BACKWARD CALORIMETERS

$$-3.6 < \eta < -1.7$$

Low  $Q^2$ , low  $x$

Physics:  
gluon saturation,  
nuclear terra  
incognita

Challenge:  
Measure the electron  
with high precision at  
small scattering  
angles

Separate the  
scattered electron  
from the nearby  
hadrons

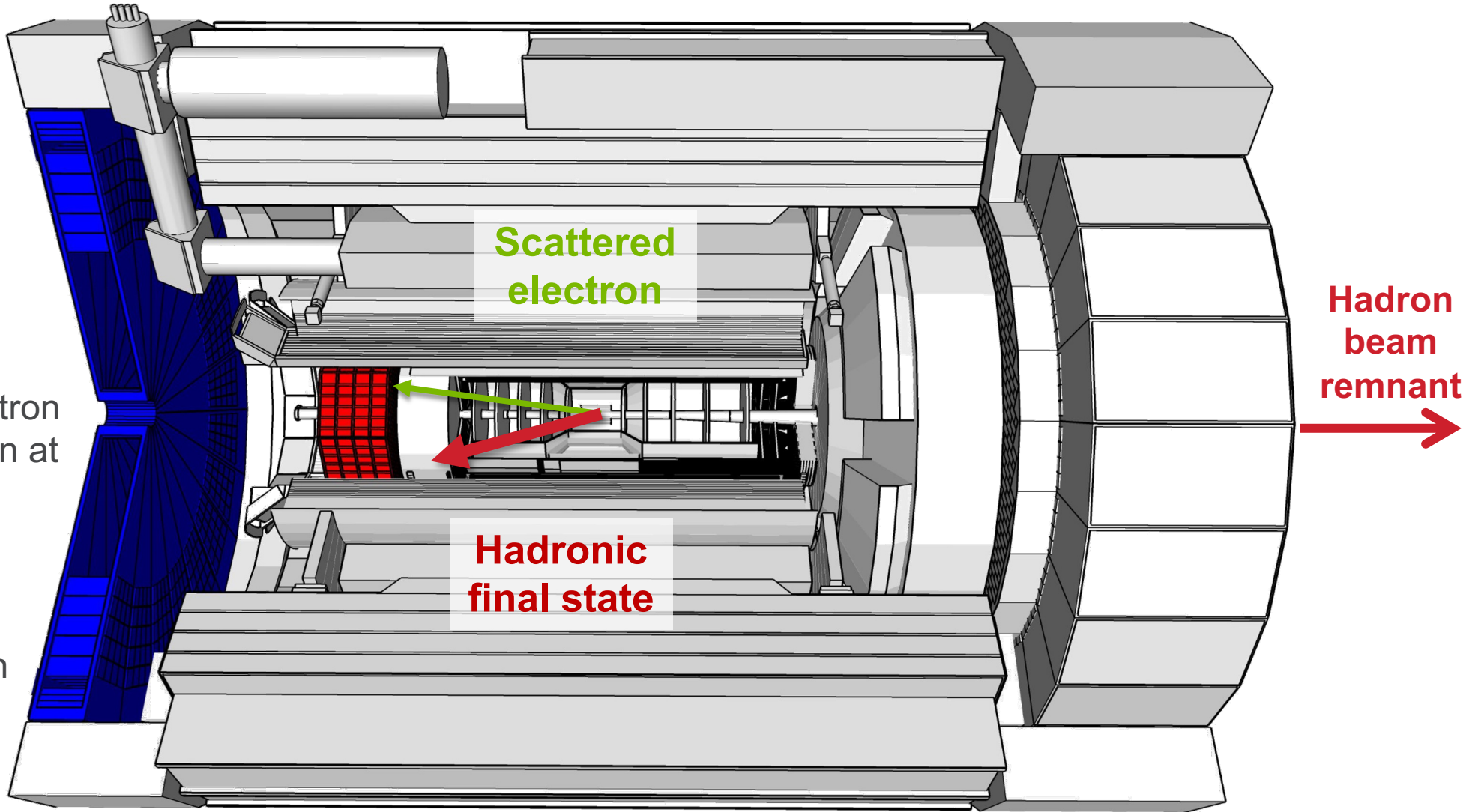

# BACKWARD CALORIMETERS

$$-3.6 < \eta < -1.7$$

Low  $Q^2$ , low  $x$

Resolution requirements:

EMCal:

$$\frac{\sigma_E}{E} \sim \frac{2-3\%}{\sqrt{E}} \oplus 1 - 2\%$$

HCal:

$$\frac{\sigma_E}{E} \sim \frac{100\%}{\sqrt{E}} \oplus 10\%$$

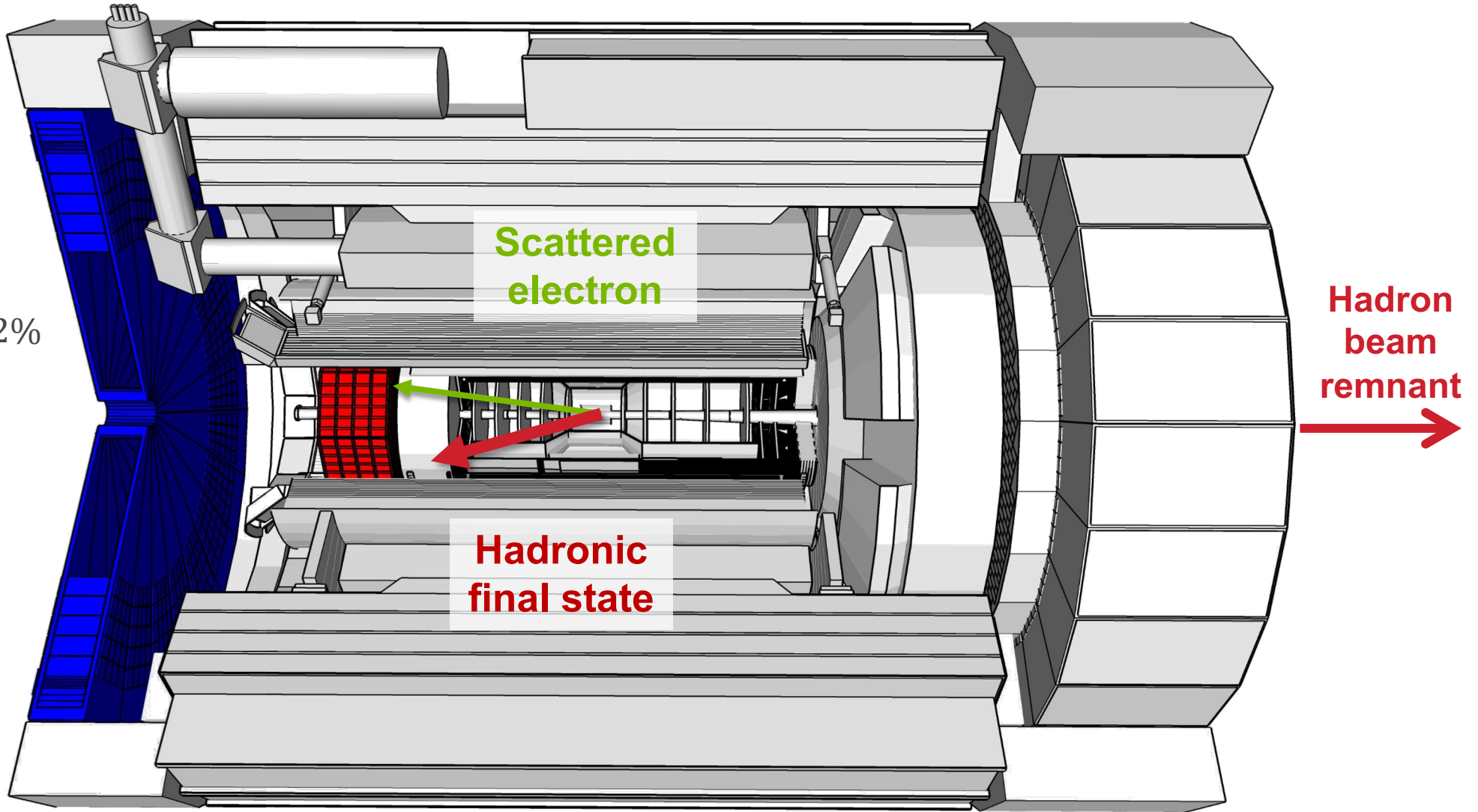



# BACKWARD ELECTROMAGNETIC CALORIMETER

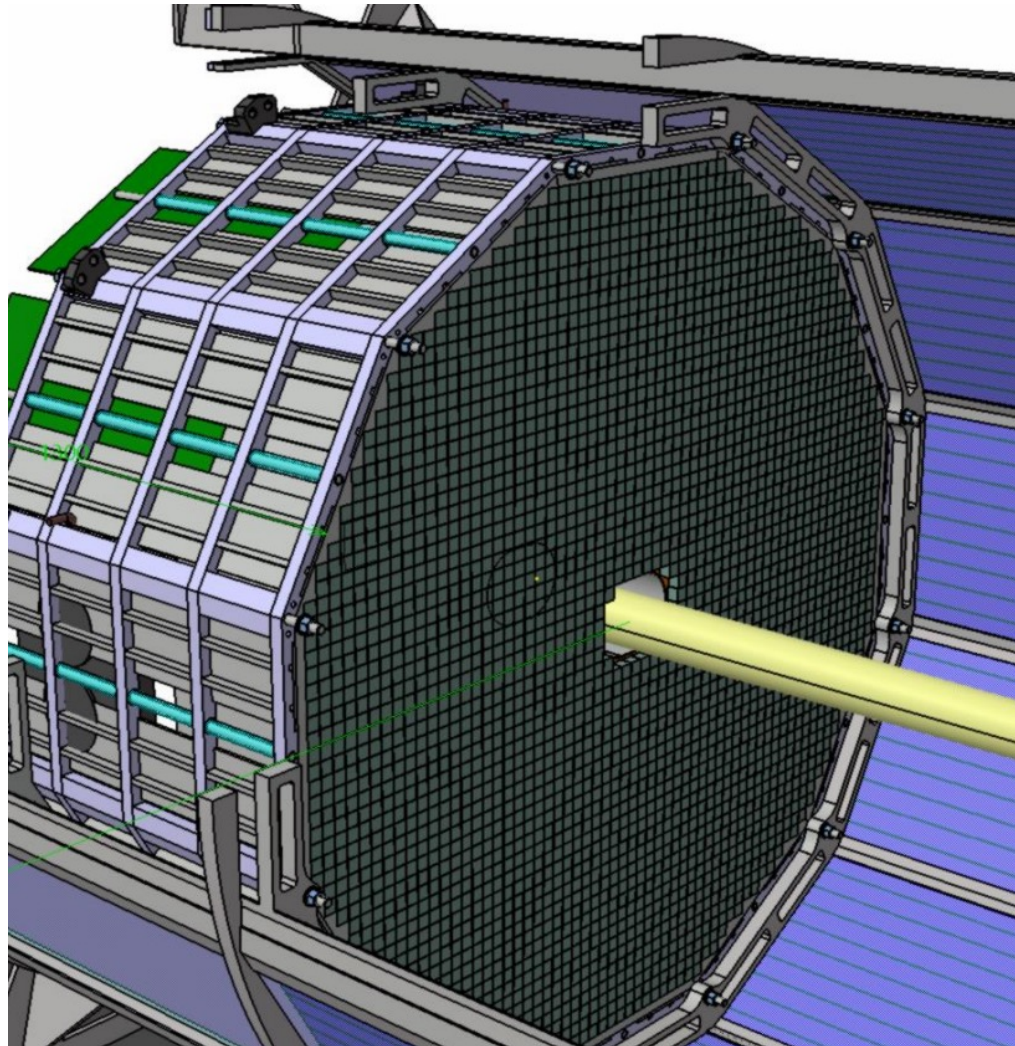
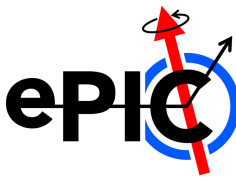

- Largest cross section for small electron scattering angles
  - Captures vast majority of scattered electrons
  - Often better resolution than tracker in this region
- Required energy resolution of  $\frac{2\%}{\sqrt{E}} \otimes 1 - 3\%$ 
  - For most electrons, dominated by constant term
  - Need precise mechanical construction & calibration techniques
- 1 in  $10^4$  pion suppression
- Detection of photons above 50 MeV
- Radiation hardness



# BACKWARD ELECTROMAGNETIC CALORIMETER

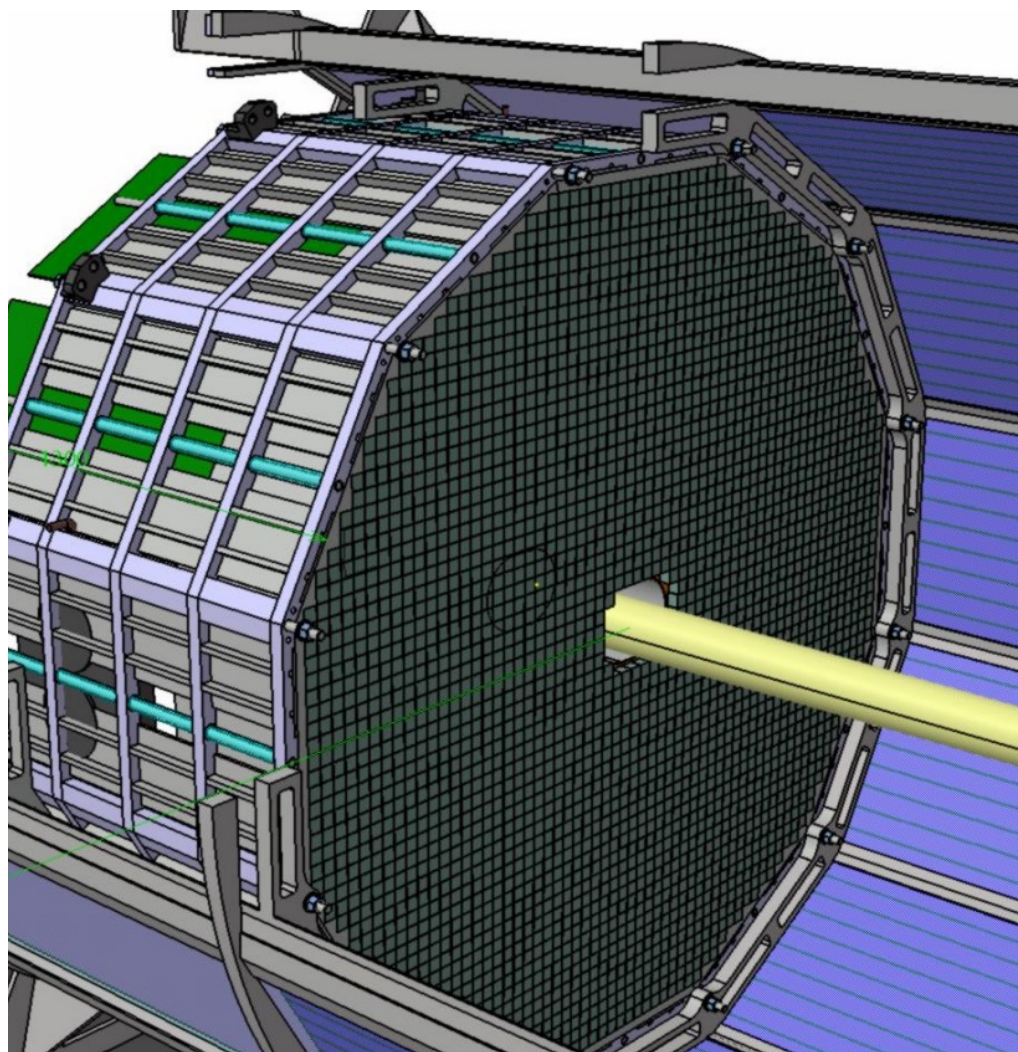

- Only realistic option to meet all of these requirements is  $\text{PbWO}_4$ 
  - High density (small Molière radius), high scintillation light yield, fast scintillation, rad hard
  - Readout via HPK S14160-3010PS SiPMs

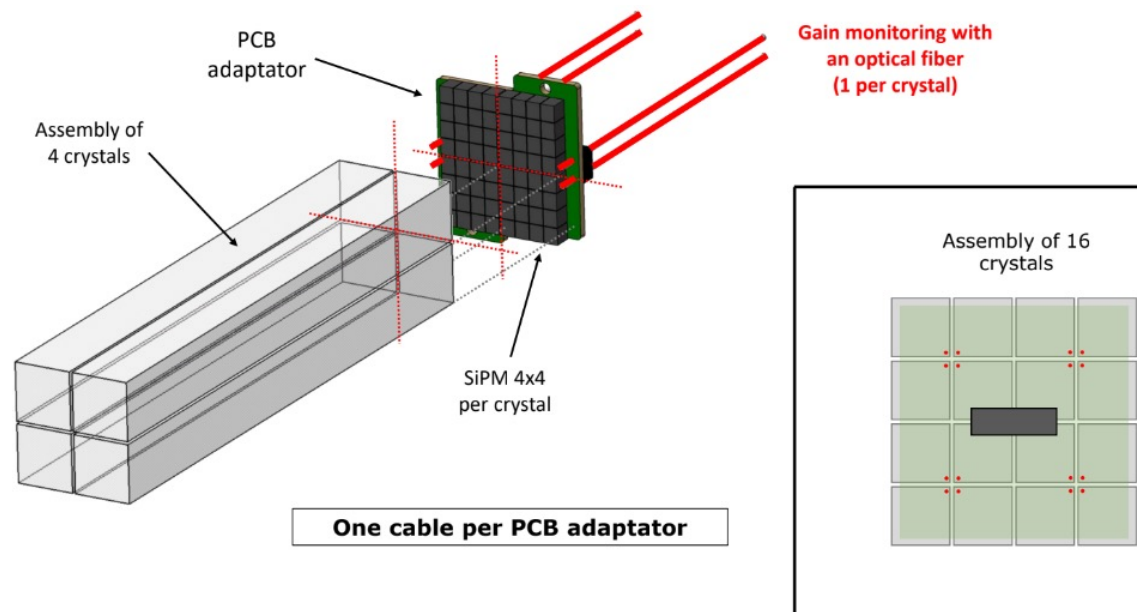



# BACKWARD ELECTROMAGNETIC CALORIMETER

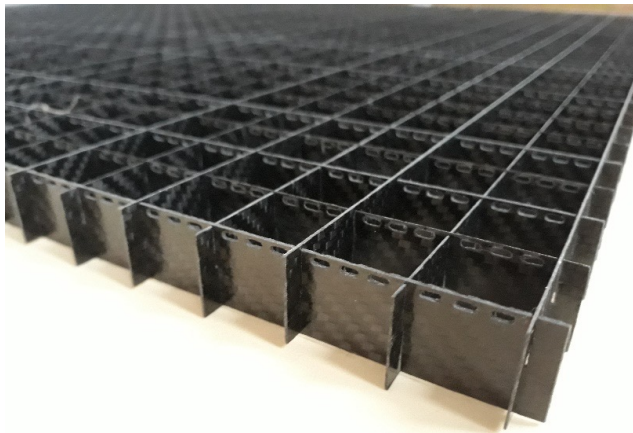
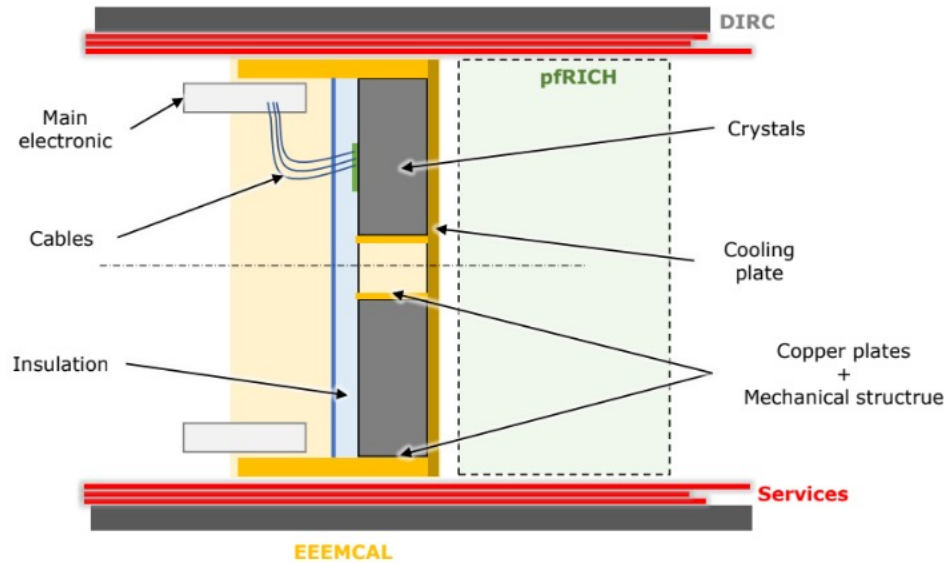
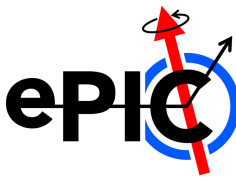

- $\text{PbWO}_4$  light yield is a strong function of temperature,  $\sim 2\%$  per  $\text{C}^\circ$ 
  - Big integration challenge, pfRICH electronics sits nearby
  - Needs temperature stability & monitoring to reach resolution goals
- Non-trivial interplay between achieving temperature stability and reducing dead material between the crystals
  - Crystals held by two 0.5 mm thick carbon fiber frames
  - One in front 2 cm of a block, one in back 2 cm
  - Air gap in-between

# BACKWARD HADRONIC CALORIMETER

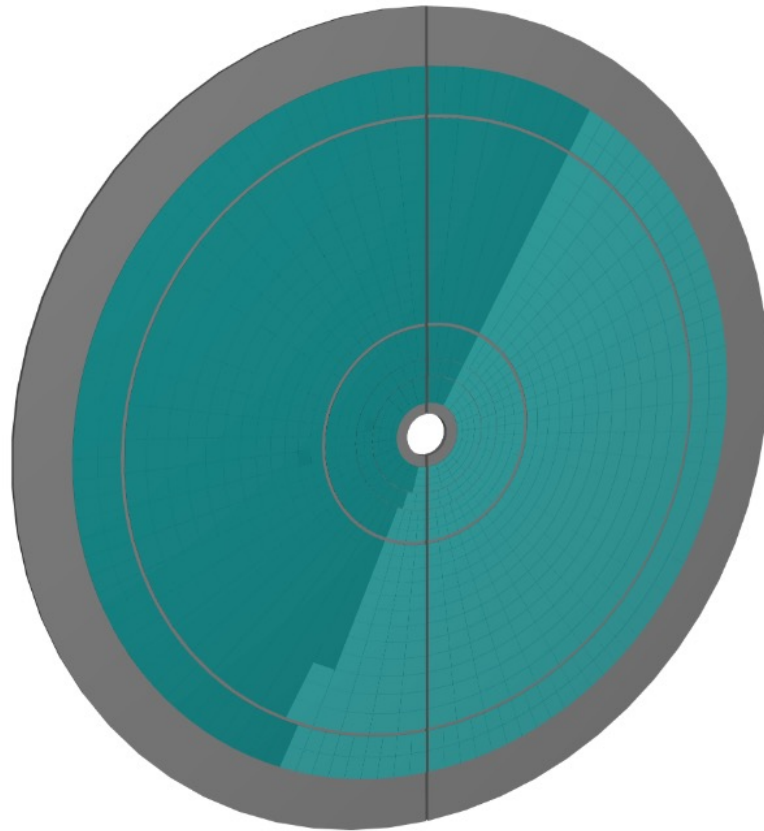
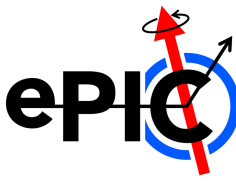

- Experience from H1 & ZEUS, backward HCal useful for improving e/h separation at low-x
  - Electron & hadrons go in the same direction, substantial overlap in the EMCal
- Low-x hadronic final state important for studying gluon saturation, typically backward-going
- Hadron energies are low, serves in part as a tail-catcher for the EMCal
  - Energy resolution requirements not stringent
  - Position resolution should be good enough to match Hcal clusters to energy deposits in Emcal
- Exact design still in progress, some combination of steel + large scintillator tiles & SiPM readout
  - Similar to BELLE KLM

# BARREL CALORIMETERS

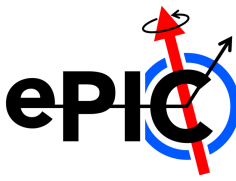

$-1.7 < \eta < 1.4$

High  $Q^2$ , Mid  $x$

Example Physics:  
DVCS, DVMP

Challenges:  
Identify components of  
hadronic final state,  
e.g. separate  $\pi^0$  from  $\gamma$

Identify low energy  $e^-$   
from high  $y$  DIS

Contain 30+ GeV  
energy  $e^-$  from high  $Q^2$

Measure low energy  $\gamma$

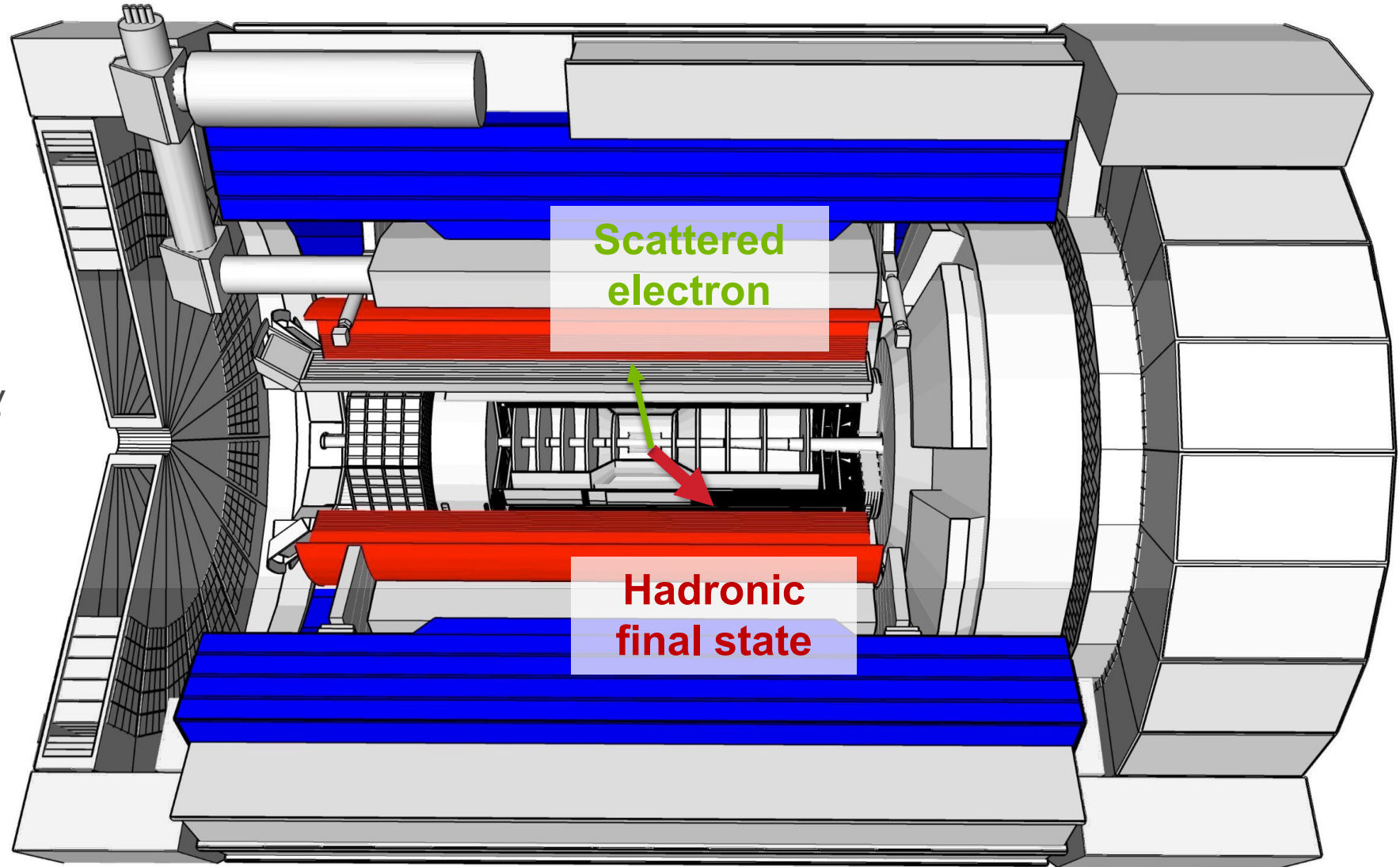

# BARREL CALORIMETERS

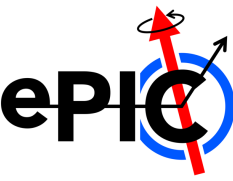

$$-1.7 < \eta < 1.4$$

High  $Q^2$ , Mid  $x$

Resolution requirements:

EMCal:

$$\frac{\sigma_E}{E} \sim \frac{10\%}{\sqrt{E}} \oplus 2 - 3\%$$

HCal:

$$\frac{\sigma_E}{E} \sim \frac{100\%}{\sqrt{E}} \oplus 10\%$$

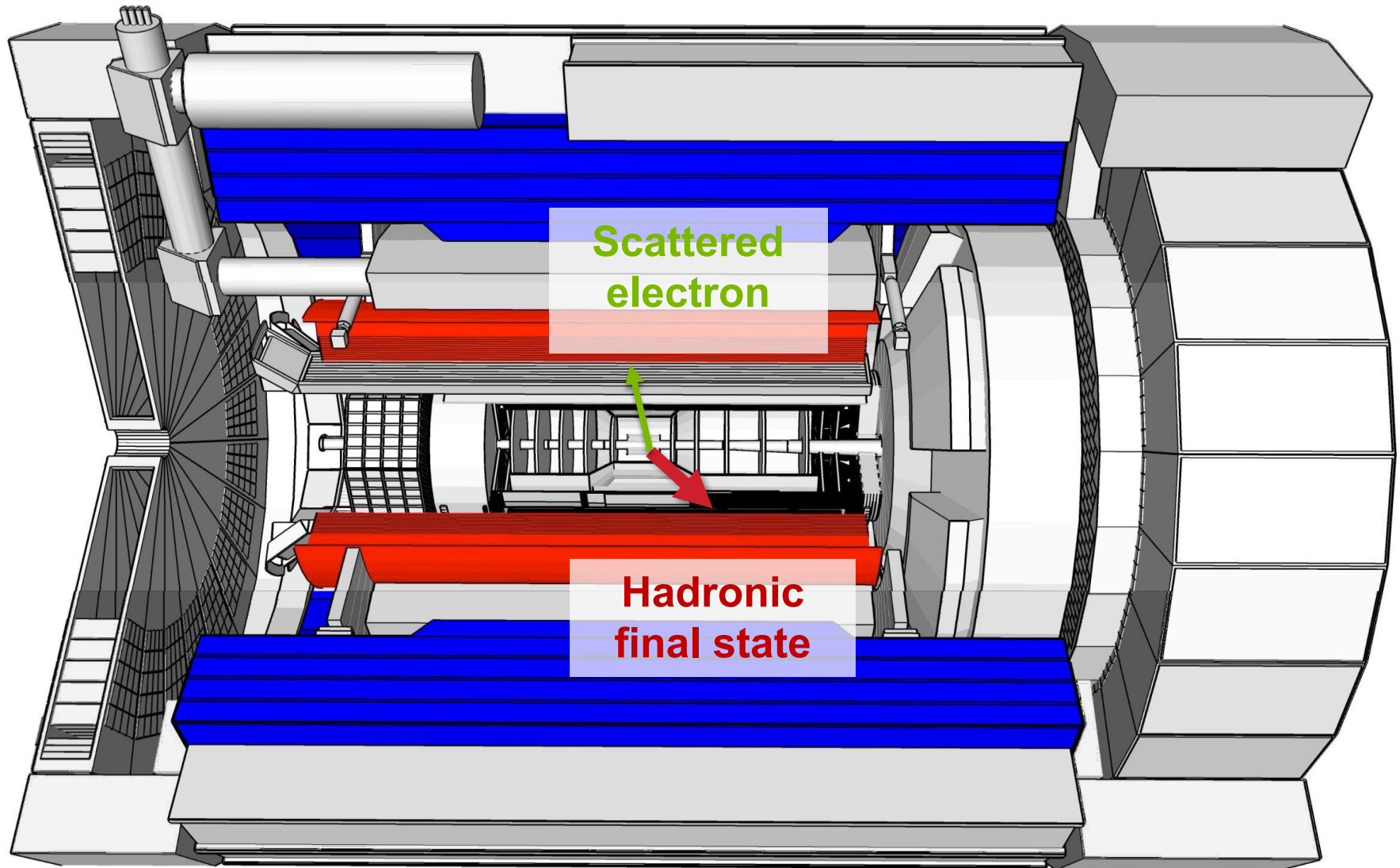



# BARREL ELECTROMAGNETIC CALORIMETER

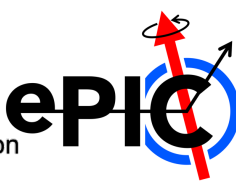

- Hybrid sampling Pb/SciFi + Silicon pixel sensor
- 4.4 m long scintillating fibers, SiPM readout on both ends
  - Longitudinally segmented
  - Similar to KLOE & GlueX
  - “Time-Projection” calorimeter -  $\Delta t \rightarrow z$
  - HGCR0C for front-end electronics
- Interleaved with layers of AstroPix MAPS silicon pixel sensors
  - Very low power consumption (few mW/cm<sup>2</sup>)
  - 500  $\mu\text{m}$  “cube” pixels
  - Good resolution ( $\sim 7\%$ ) on energy deposited in pixel

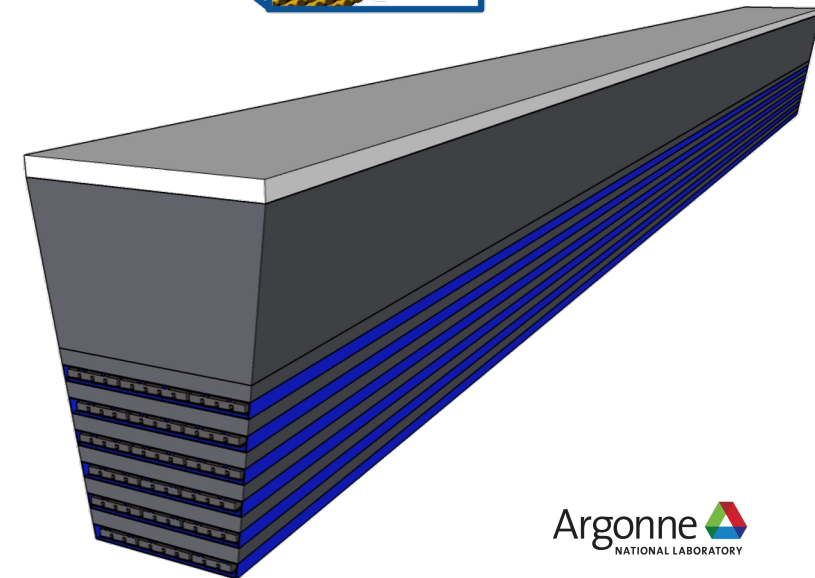
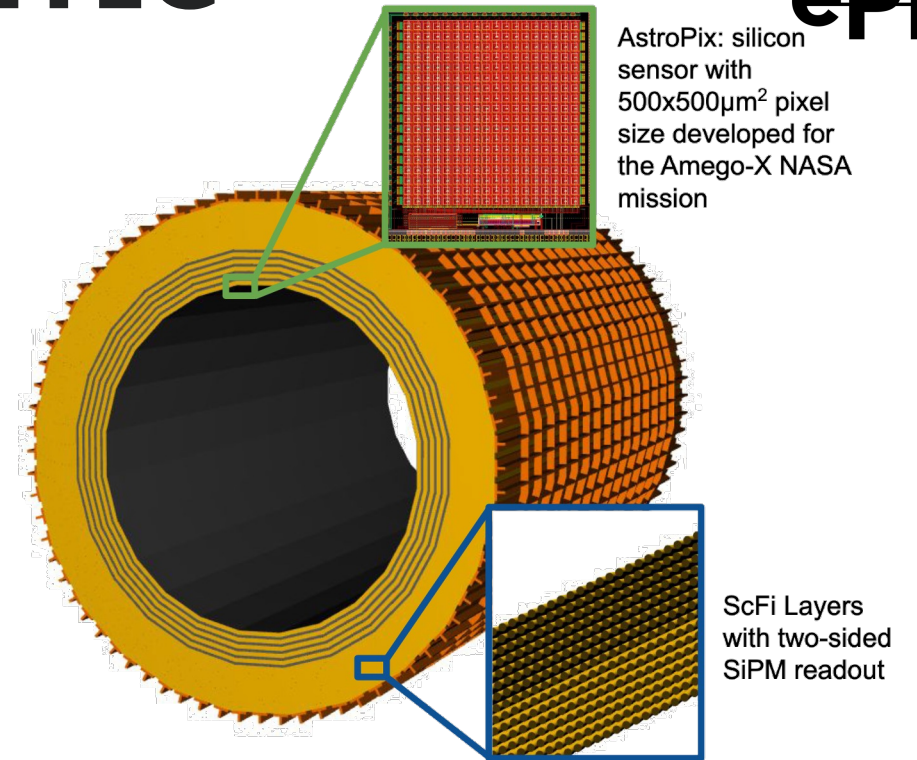



# BARREL ELECTROMAGNETIC CALORIMETER

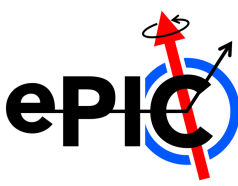

SiPM Readout Scheme  
Light guides to 1.2x1.2 cm SiPMs

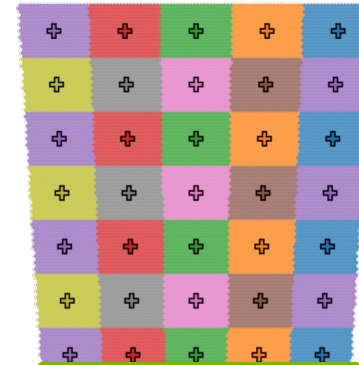
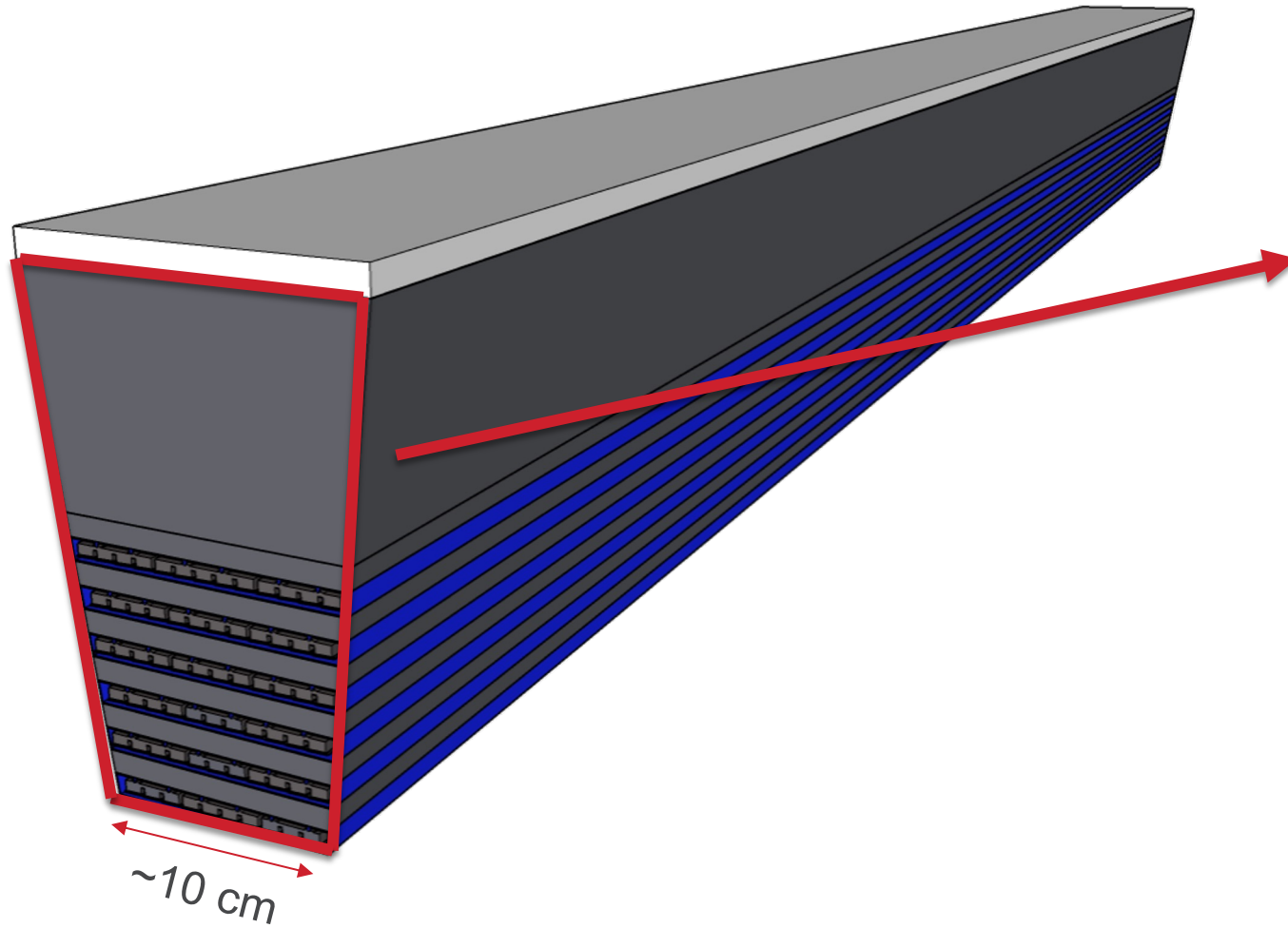

AstroPix Tiling Options

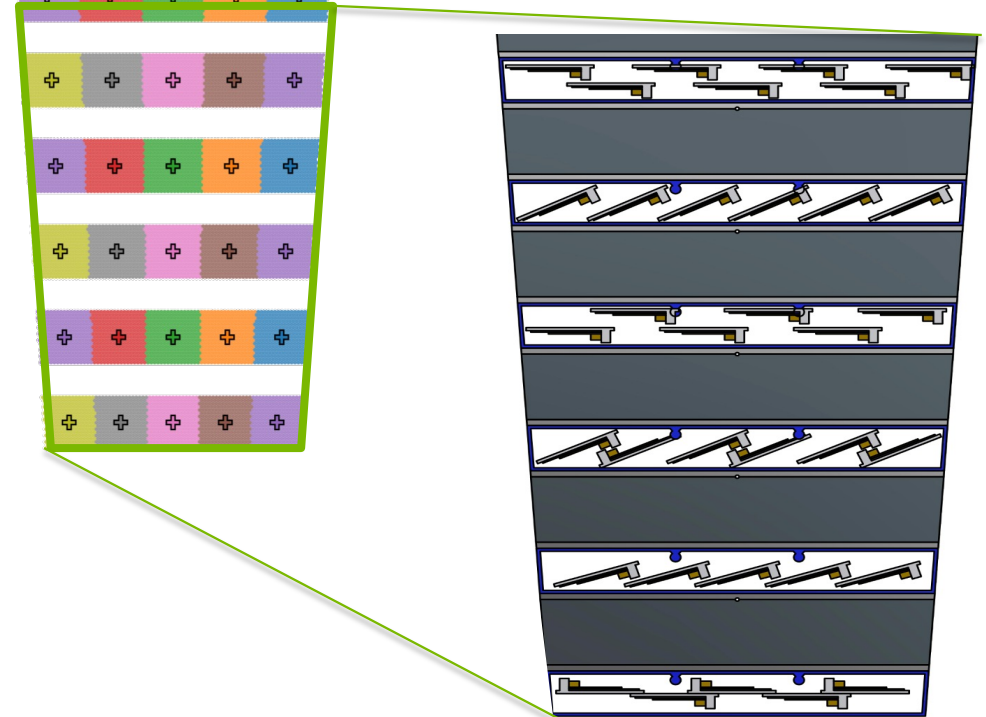

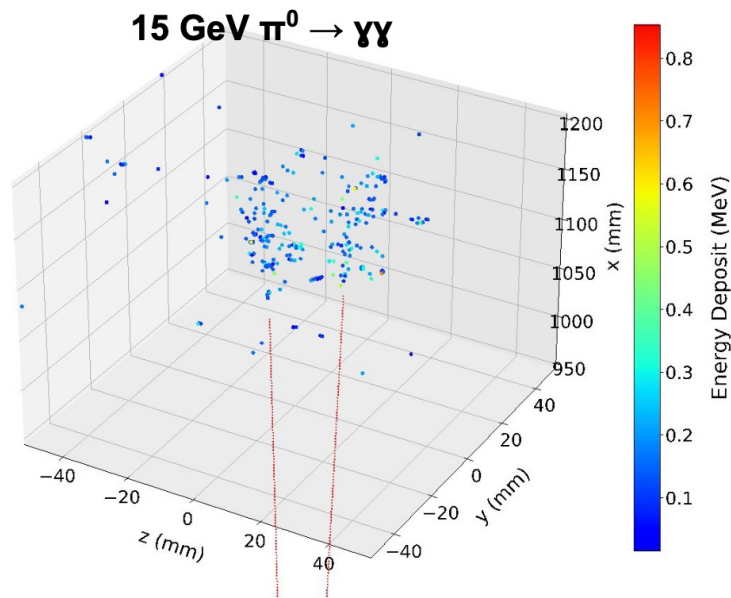

15 GeV  $\pi^0 \rightarrow \gamma\gamma$

### Separation of $\gamma/\pi^0$ (upper limit)

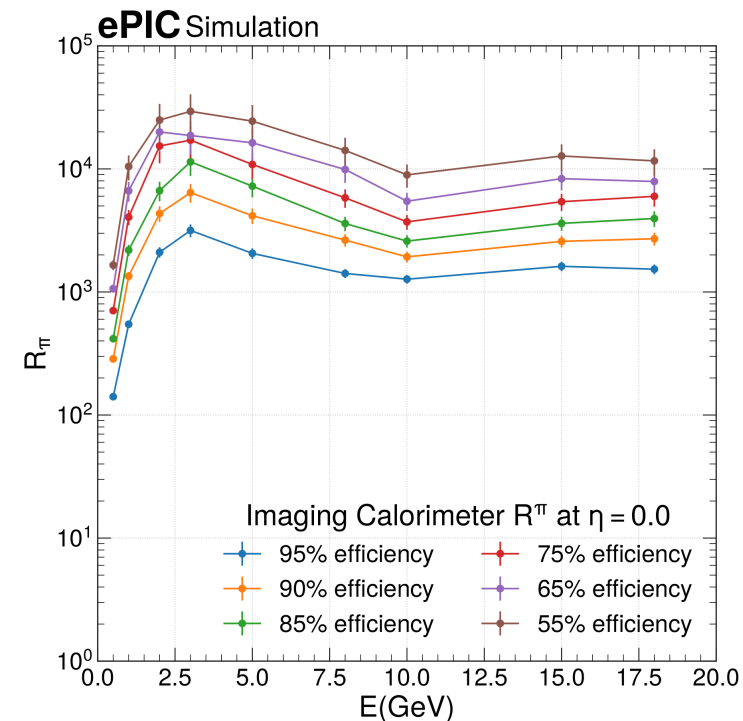
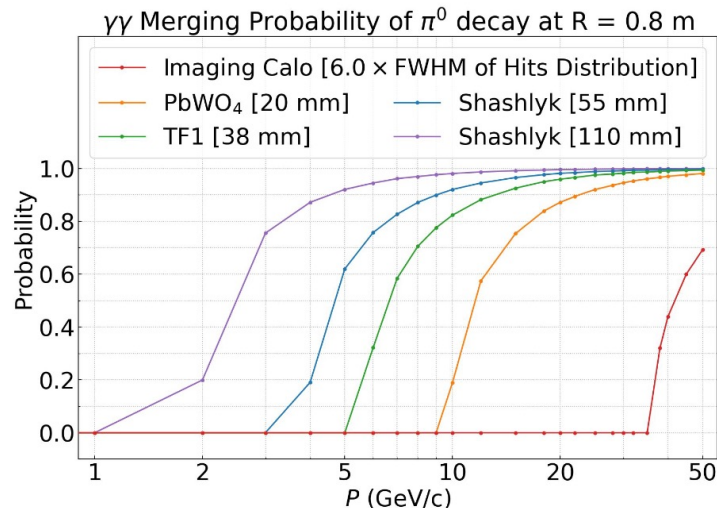

- Interleaving of AstroPix sensors allow for excellent position resolution
  - Angular resolution on the order of 0.1 degree
  - Separate  $\pi^0$  from  $\gamma$  beyond 30 GeV
  - Can do vertexing on photons!
- Very effective separation of electrons from hadrons based on shower shape discrimination
  - Still quite effective at  $\sim 1$  GeV & below

# BARREL HADRONIC CALORIMETER

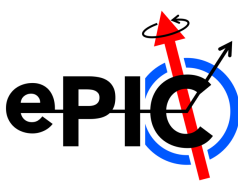

- Modest requirements on energy resolution
  - $\sim 100\%/\sqrt{E}$
  - Hadrons in barrel typically low energy ( $<5$  GeV), better measured by tracking
  - Tag jets with large neutral hadron component
- Measure muons from e.g.  $J/\psi \rightarrow \mu\mu$
- Reuse from sPHENIX

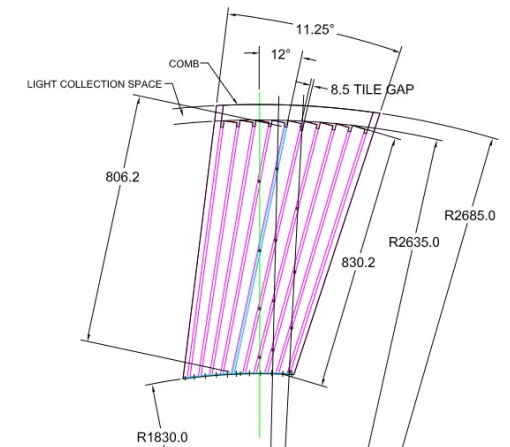
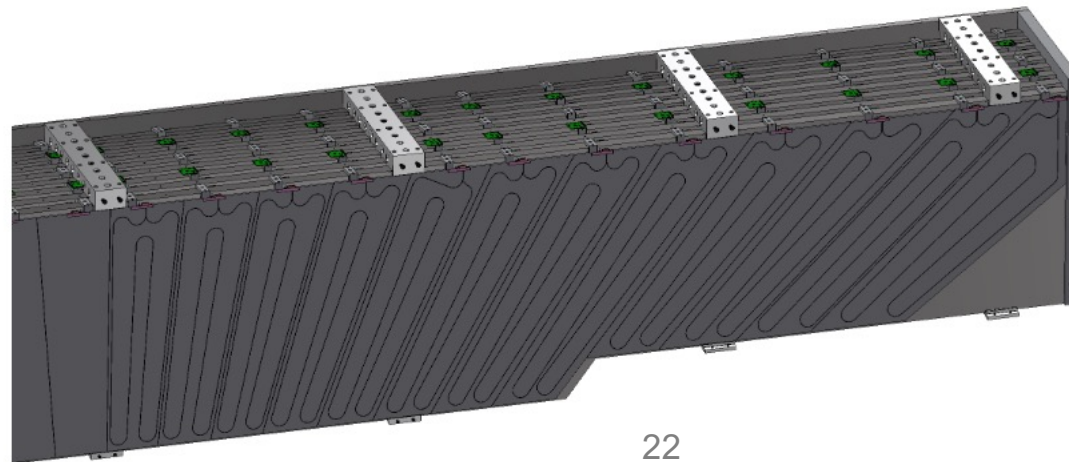



# BARREL HADRONIC CALORIMETER

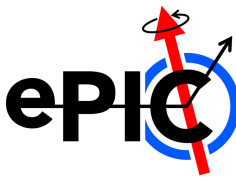

- Steel/Scintillator design
  - Steel plates tiled at an angle to prevent channeling
  - Straight tracks have a sizable path length through scintillator, good for MIP detection
  - Readout via HPK S12572 series SiPMs
- Refurbish for EIC
  - Expect minor radiation damage from sPHENIX, can replace SiPMs with HPK S14 series
  - Upgrade electronics to HGCROC
  - Increase segmentation by reading out each tile individually

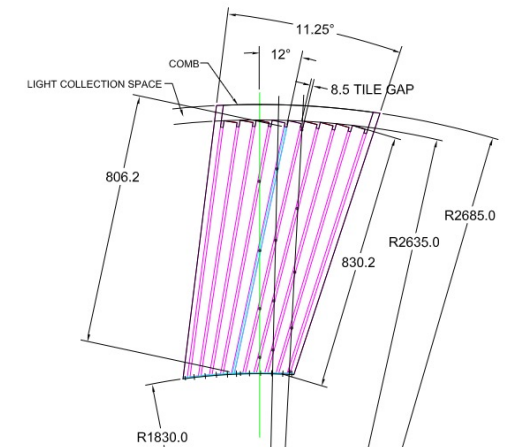
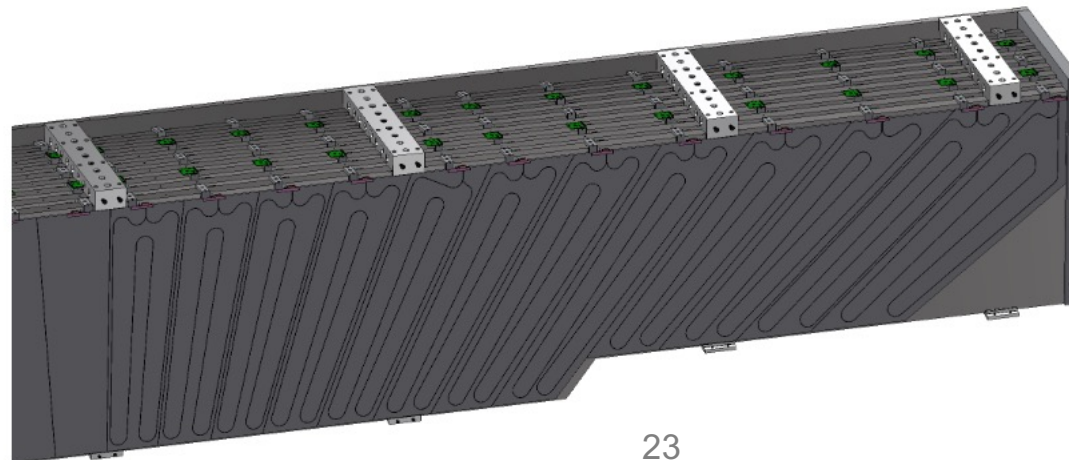

# FORWARD CALORIMETERS

$$1.4 < \eta < 4$$

High  $Q^2$ , High  $x$

Example Physics:  
TMDs, Jets, SIDIS

Challenges:  
Contain the highly energetic hadronic final state

Separate clusters in a dense hadronic environment

Highest radiation load near hadron beam

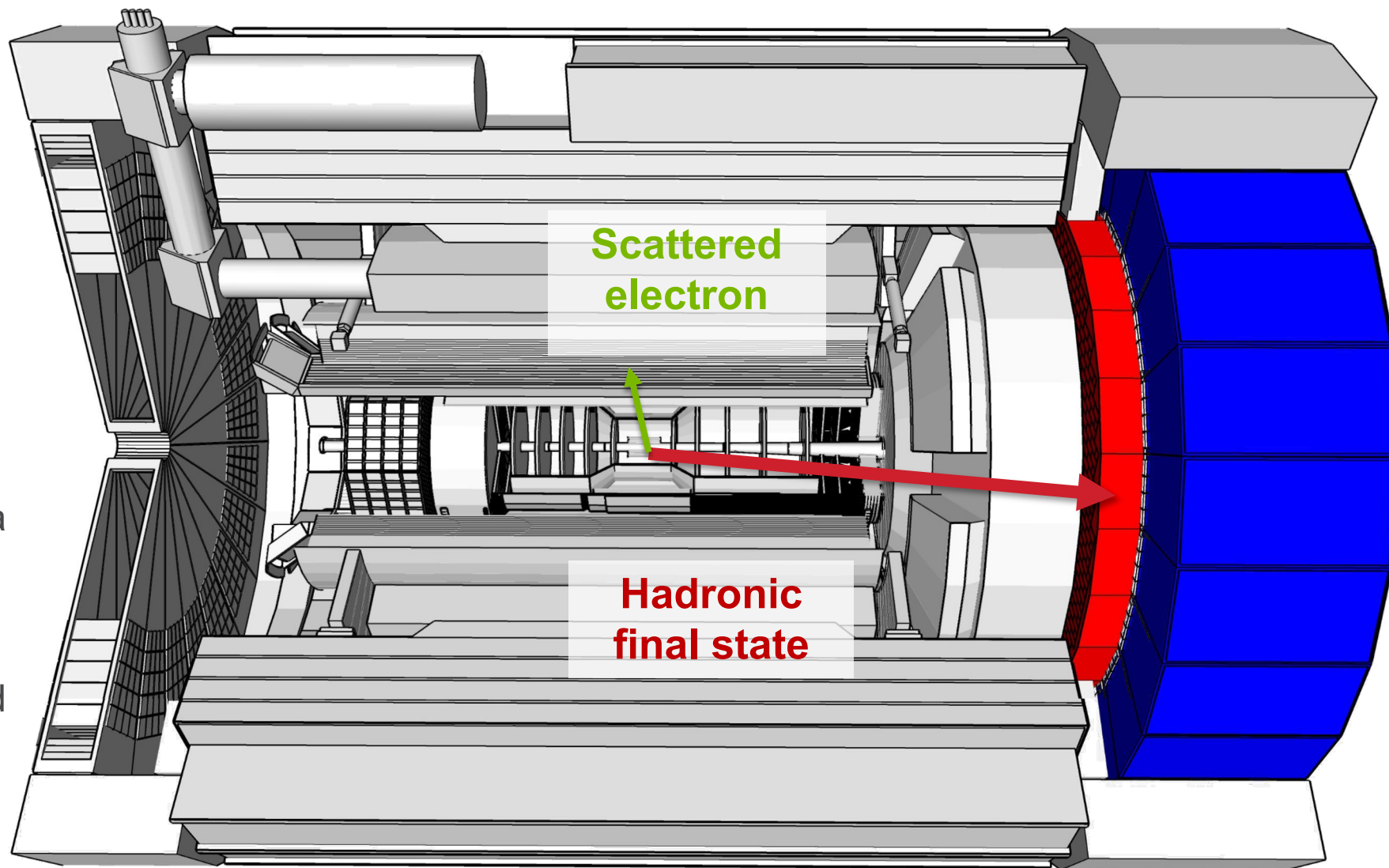



# FORWARD CALORIMETERS



$$1.4 < \eta < 4$$

High  $Q^2$ , High  $x$

Resolution requirements:

EMCal:

$$\frac{\sigma_E}{E} \sim \frac{10\%}{\sqrt{E}} \oplus 2 - 3\%$$

HCal:

$$\frac{\sigma_E}{E} \sim \frac{50\%}{\sqrt{E}} \oplus 10\%$$

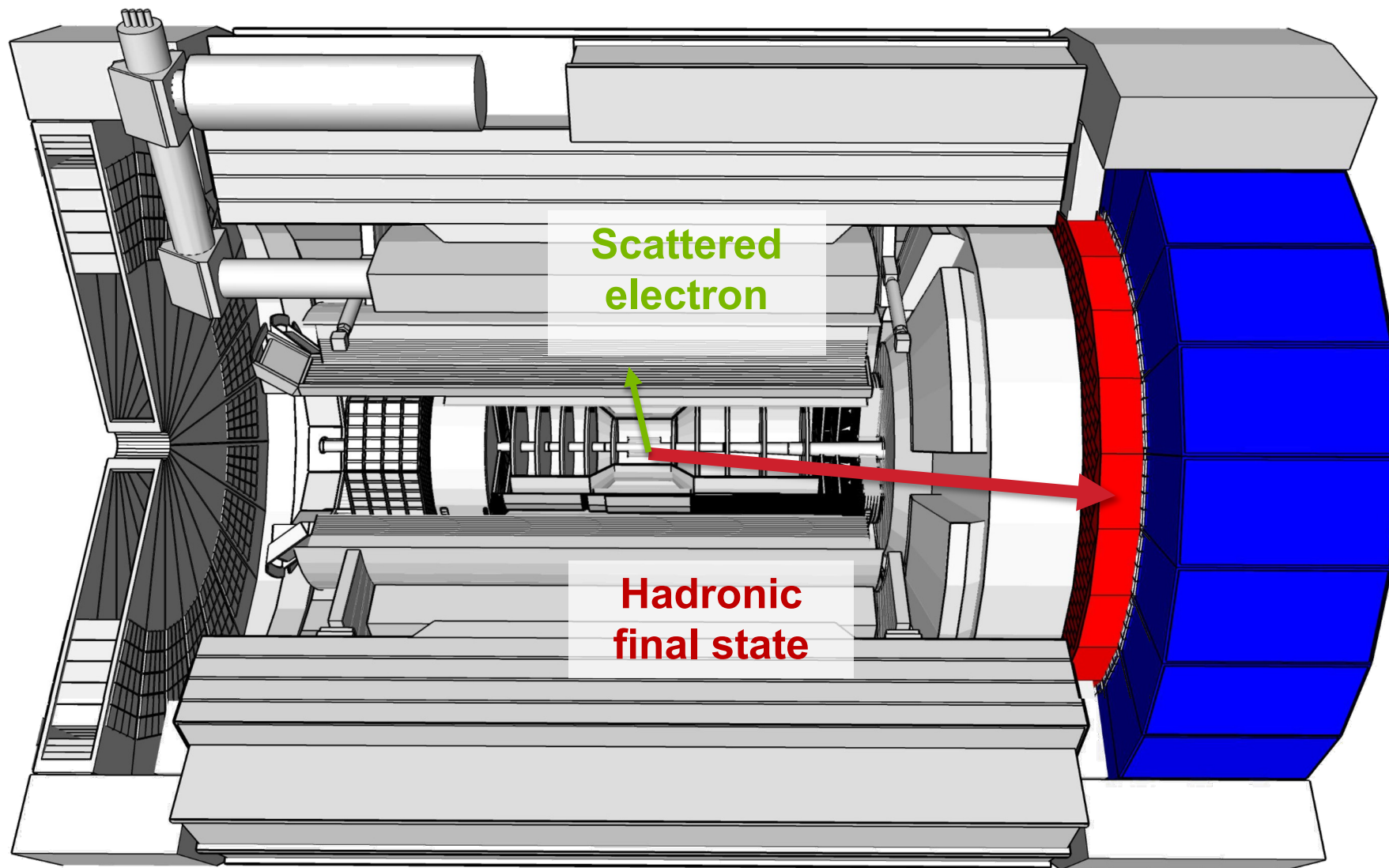

# FORWARD ELECTROMAGNETIC CALORIMETER

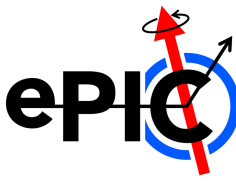

- Tungsten + SciFi SPACAL design
  - Developed through EIC R&D and applied successfully in sPHENIX EMCAL
  - Tungsten powder mixed with epoxy
- Position resolution vital to separate  $\pi^0$  from  $\gamma$  at high energy
  - Dense absorber ( $\sim 10 \text{ g/cm}^3$ )
  - Readout with many SiPMs to create a small tower size
- Uniformity of construction important to reduce constant term
  - Dominates at high energy
  - Powder + epoxy enables fine control over spatial distribution of scintillator

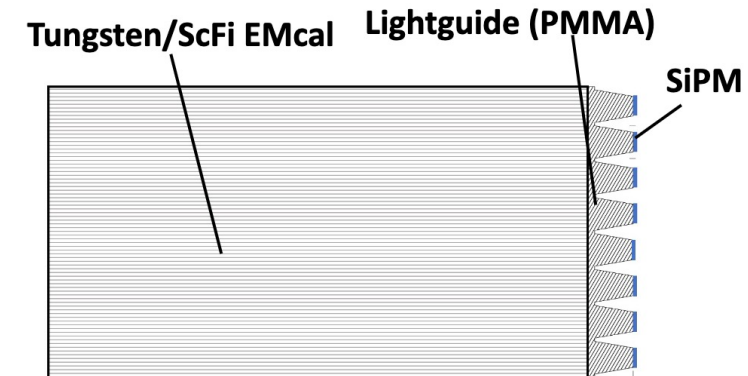
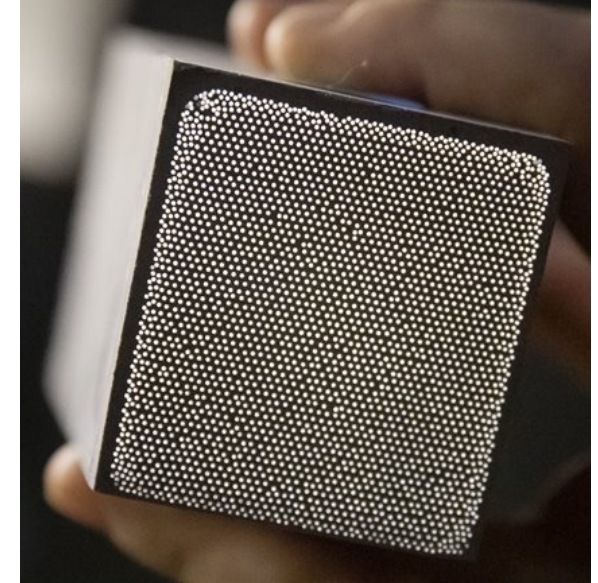

# FORWARD ELECTROMAGNETIC CALORIMETER

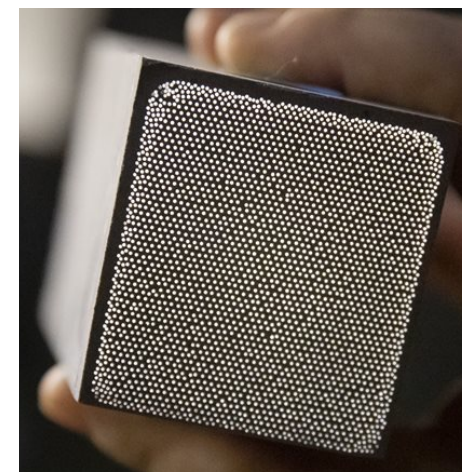
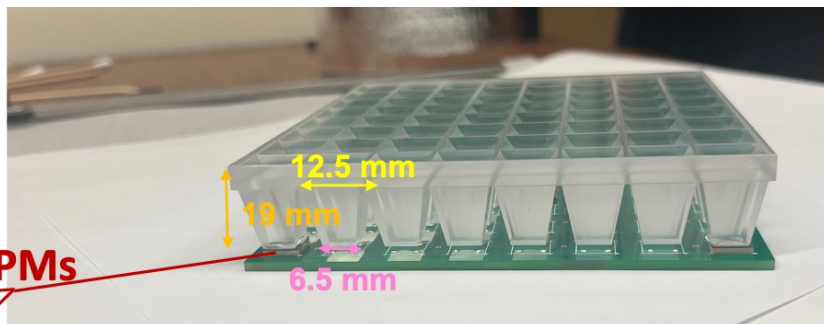
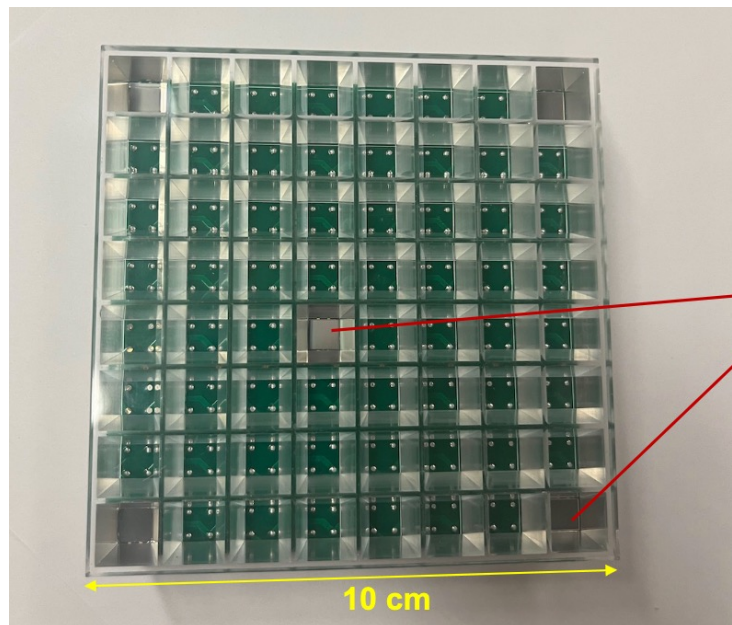

SiPMs

- 5 cm x 5 cm x 17 cm blocks of absorber + fibers
  - Four independent towers per block
- Each 2.5 x 2.5 cm tower is readout by four 6x6mm HPK S14 series SiPMs
- Expected energy resolution  $\sim \frac{10\%}{\sqrt{E}} \oplus 1 - 3\%$

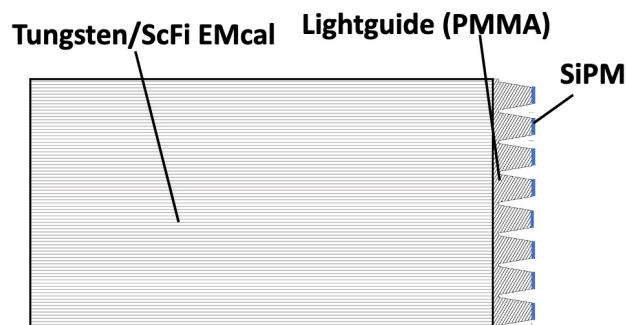



# FORWARD HADRONIC CALORIMETER

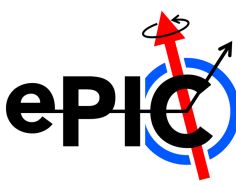

- Steel + Scintillator SiPM-on-tile
  - Pioneered by CALICE analog HCal
  - Ideal for particle-flow measurements!
- Highly segmented longitudinally, 65 layers per tower
  - 565,760 SiPMs
  - 7 layers summed to one readout channel
- Stackable for “easy” construction
  - Steel as absorber significantly simplifies design, improves material uniformity
  - Achieves  $\sim 6.5 \lambda_0$
- Expected resolution  $\sim \frac{45\%}{\sqrt{E}} \oplus 5\%$ 
  - Exceeds requirements defined by Yellow Report!

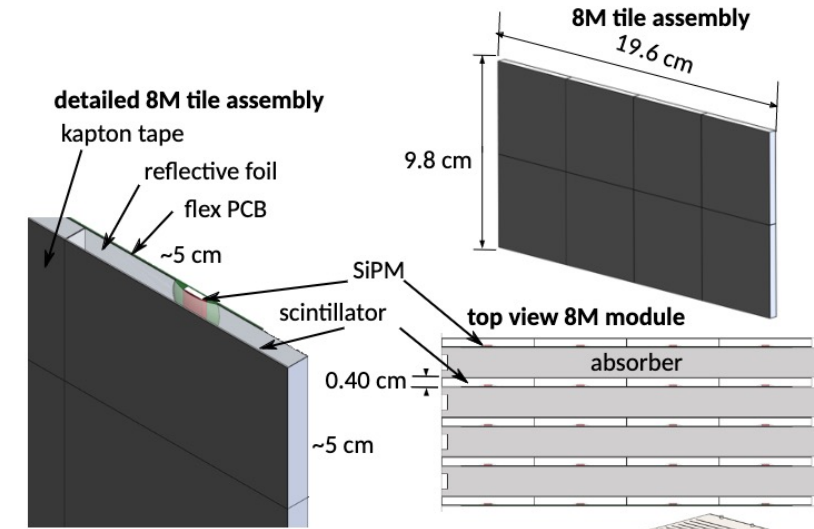
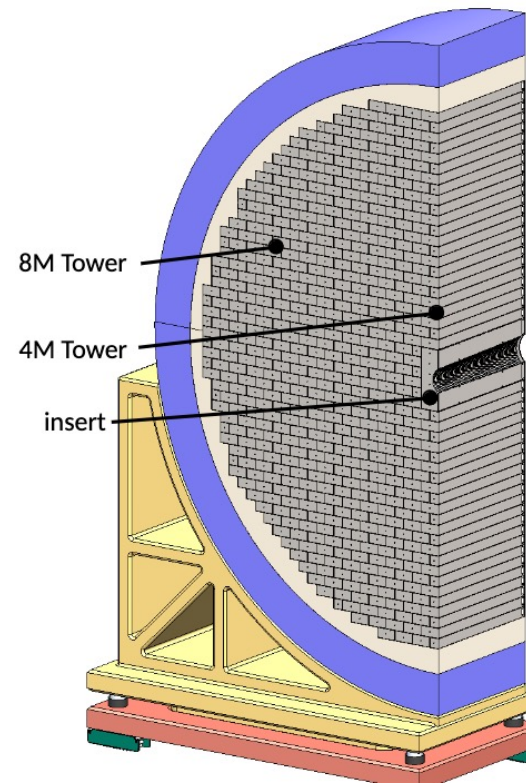

Stacking design

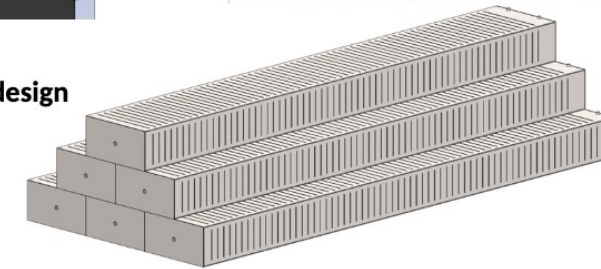



# FORWARD HADRONIC CALORIMETER

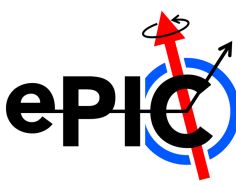

- SiPMs mounted to thin flex PCBs
  - Signals routed along PCB to periphery
- Signals brought to HGCRROC at back by a thin flex PCB that runs longitudinally alongside the tower

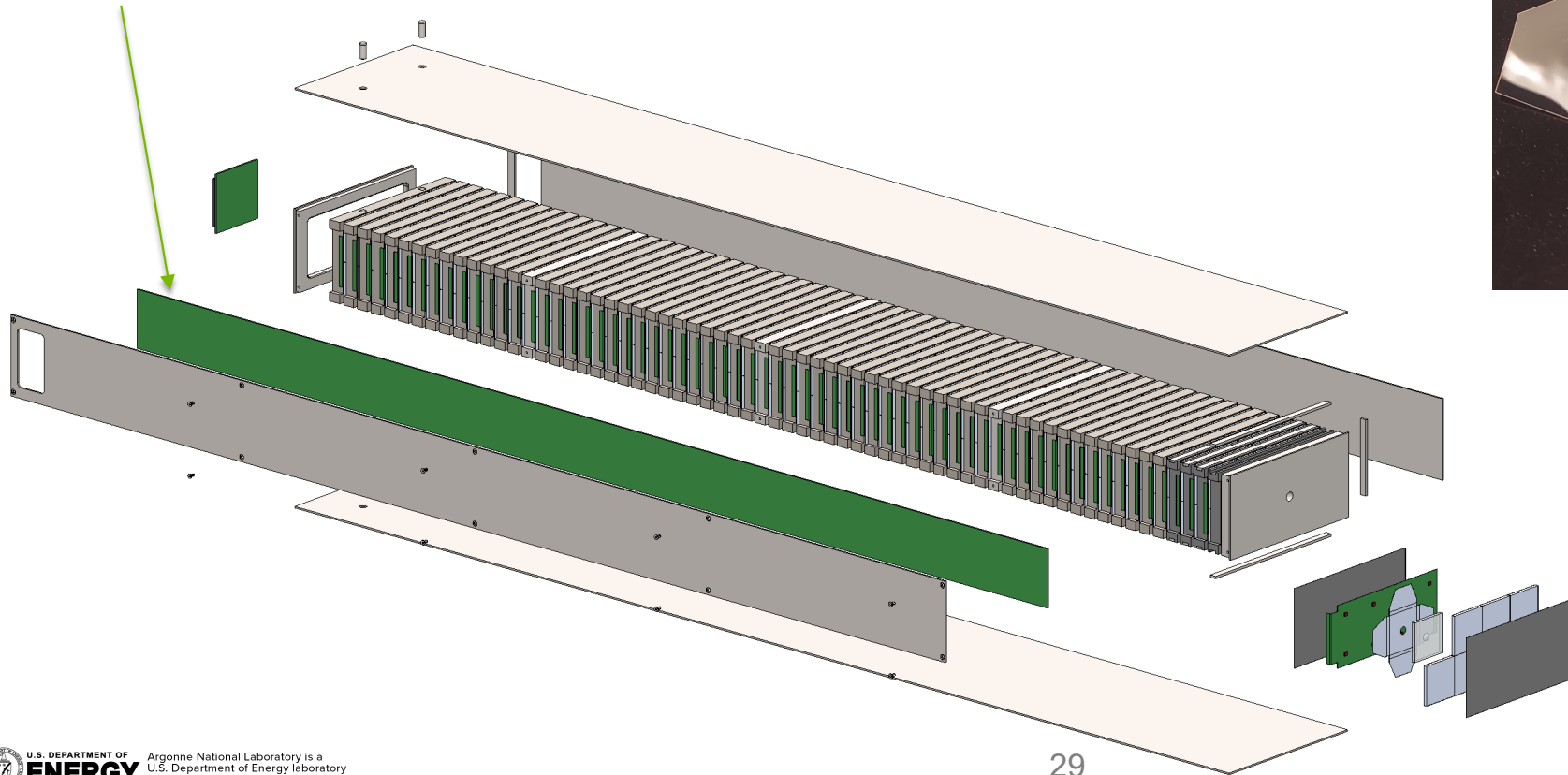
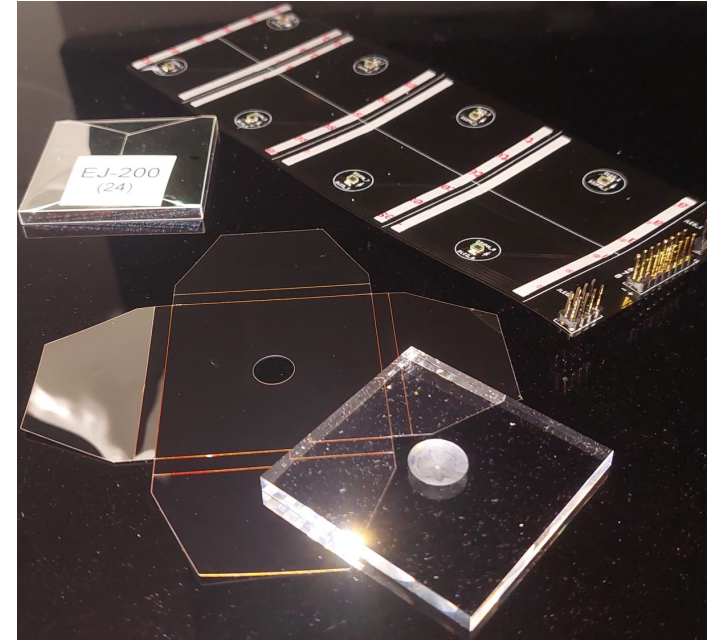

# FORWARD INSERT CALORIMETER

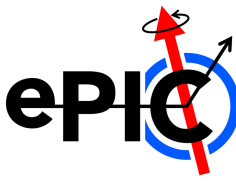

- Insert to extend central detector acceptance as much as possible in the forward direction
  - Crucial for containment of hadronic final state for inclusive kinematic reconstruction and rapidity gap diffractive measurements
  - $3.2 < \eta < 4$
  - Needs to accommodate complex beam pipe geometry
- Small hexagonal scintillator tiles for better spatial uniformity & increased light yield
- High radiation load
  - SiPMs will be serviceable
  - $\sim 10^{12}$  neq/cm<sup>2</sup>/year

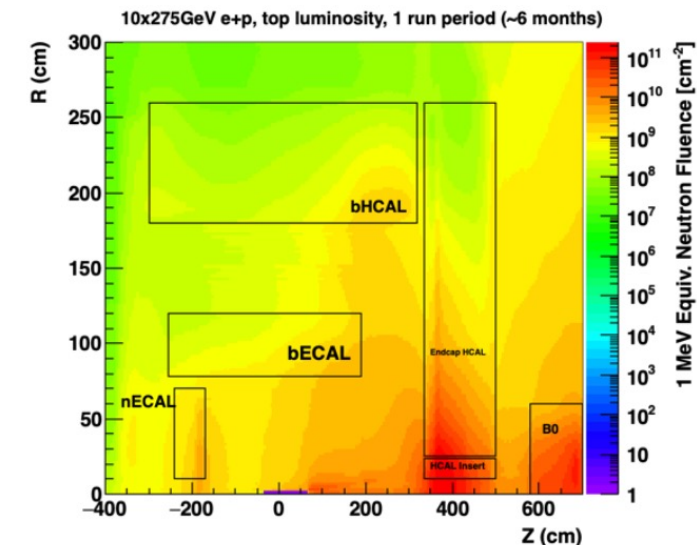
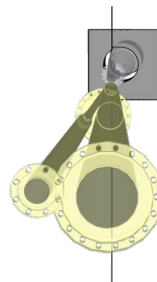
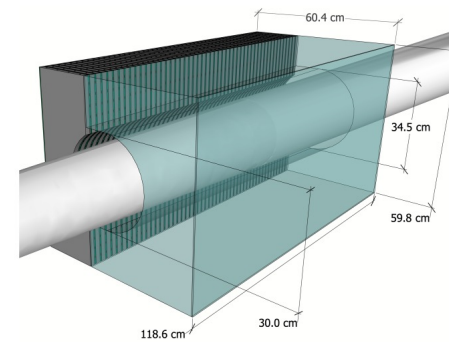
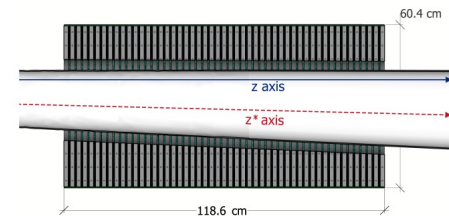
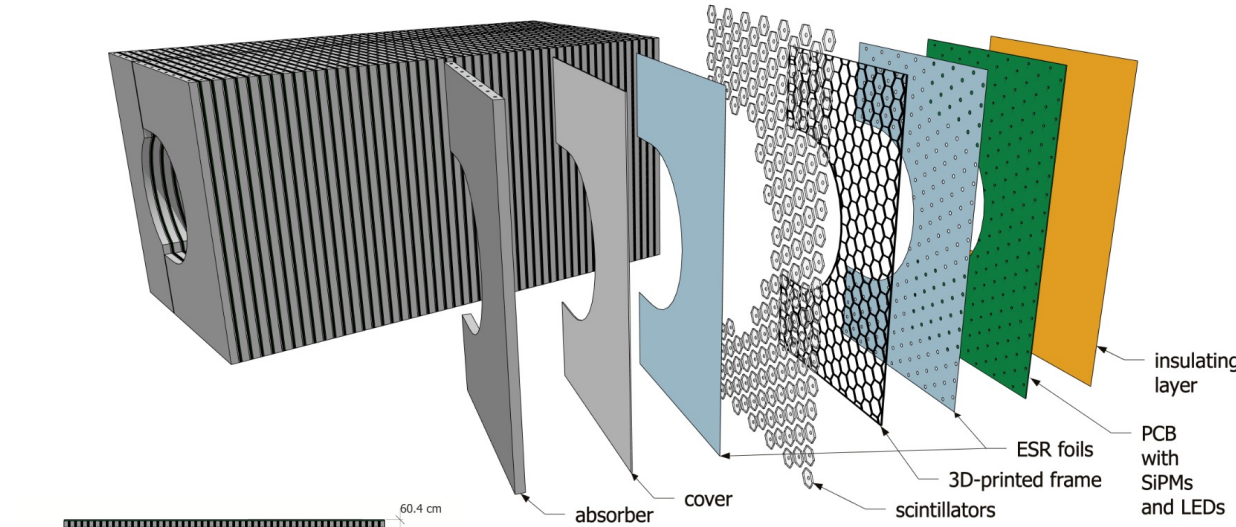

# PERFORMANCE PROJECTIONS

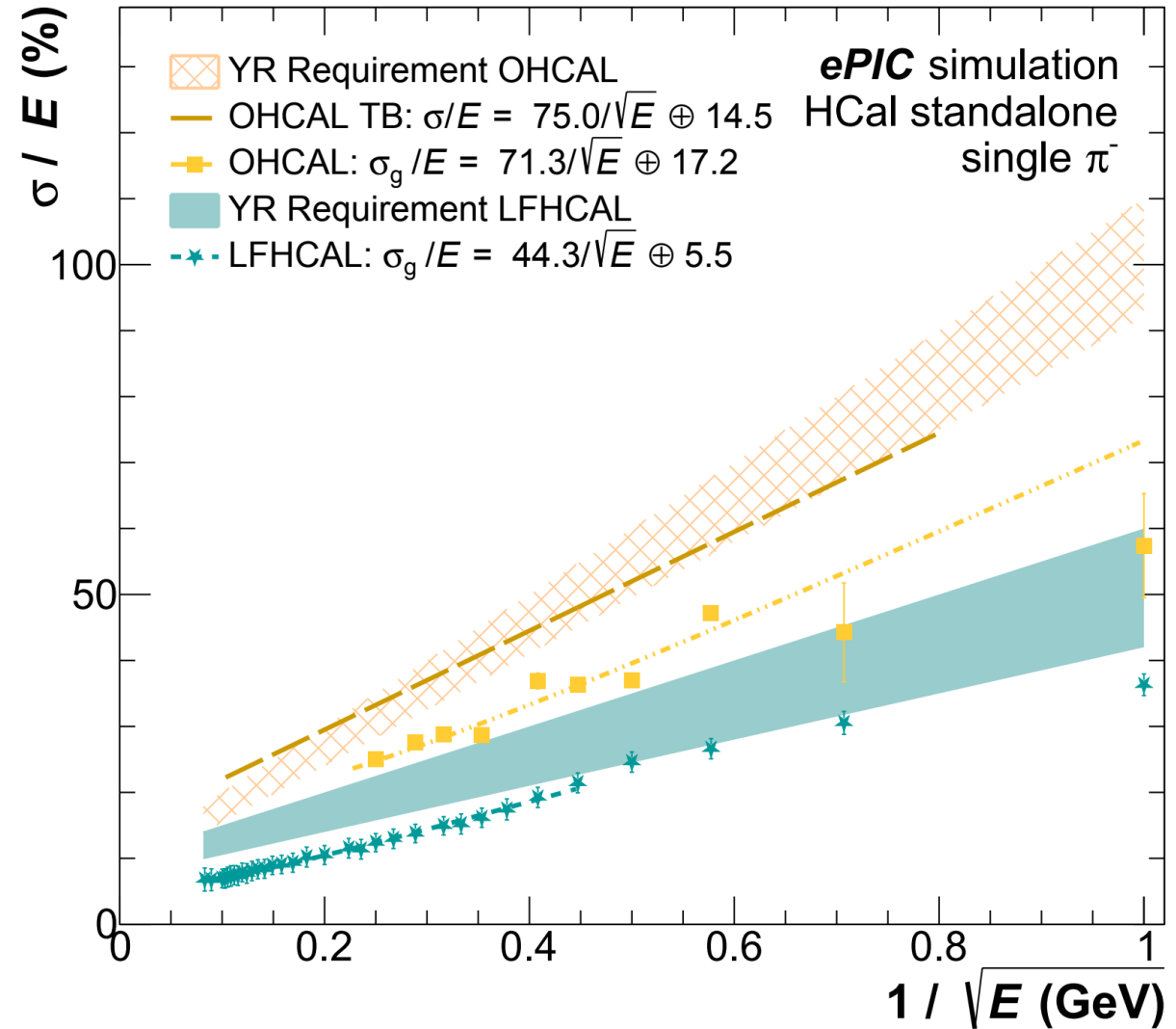
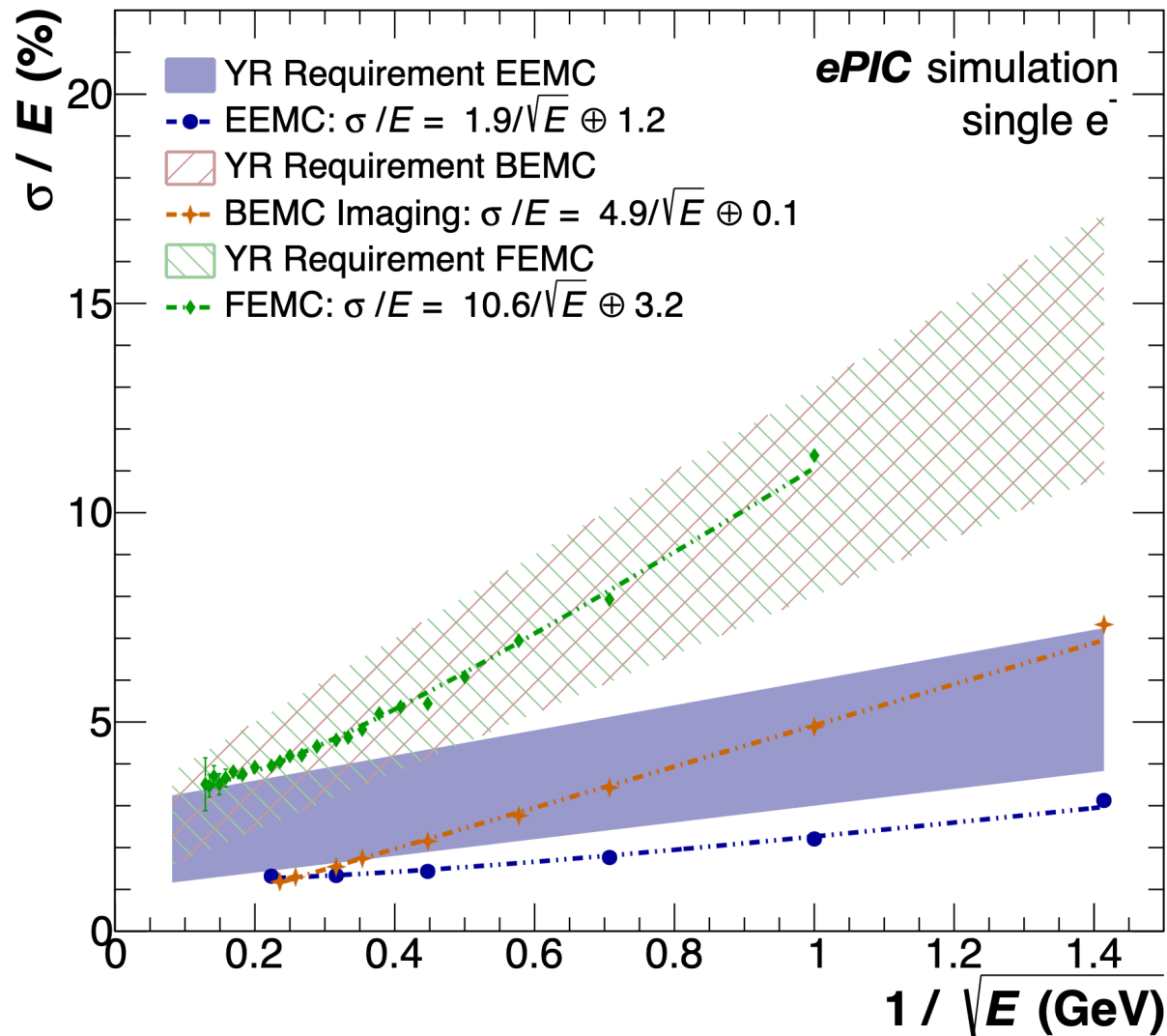
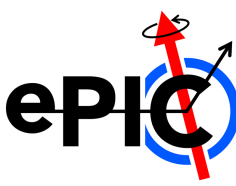

# CONCLUSION

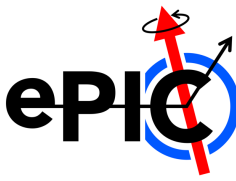

- Calorimetry is a vital component of the EIC detector package
- ePIC employs unique calorimetry designs to meet the varied demands of the different detector regions
  - Designed to meet the multifarious challenges & physics of the EIC!
- The ePIC calorimeter designs meet or exceed their performance requirements!
- EIC is scheduled to begin running in 2032
  - CD3 & Construction to begin in earnest in 2025
- **ePIC TDR coming soon, stay tuned!**

Thanks to everyone who provided the information for this talk!

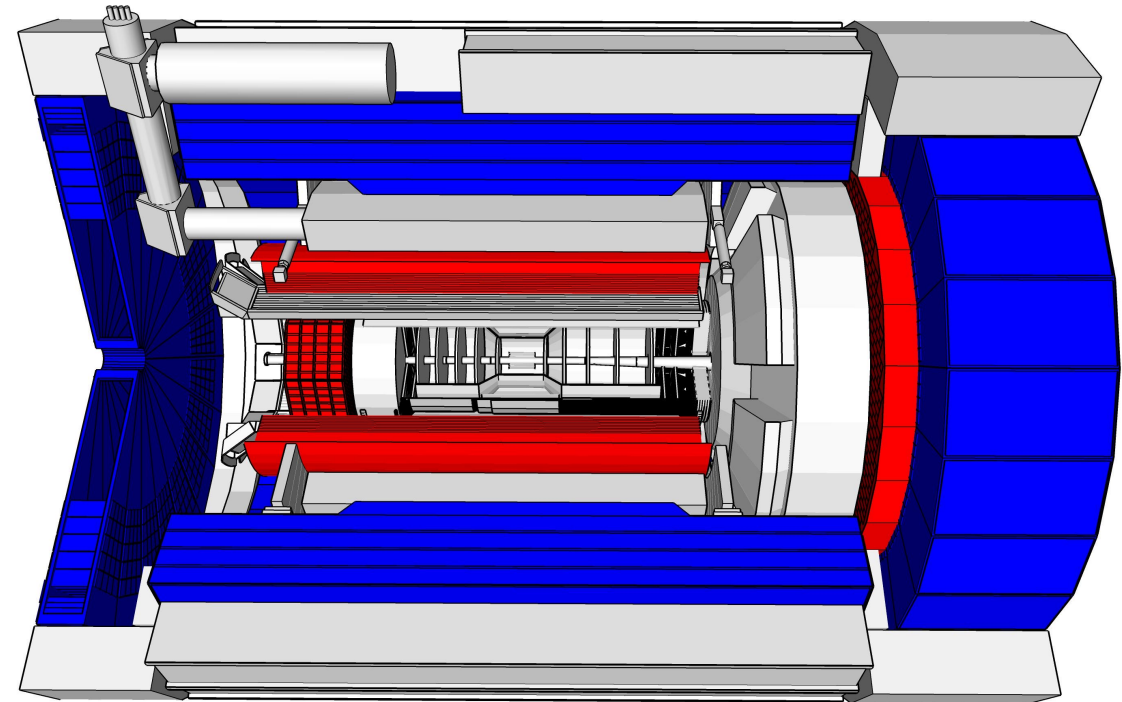

Thank you!



# BACKUP

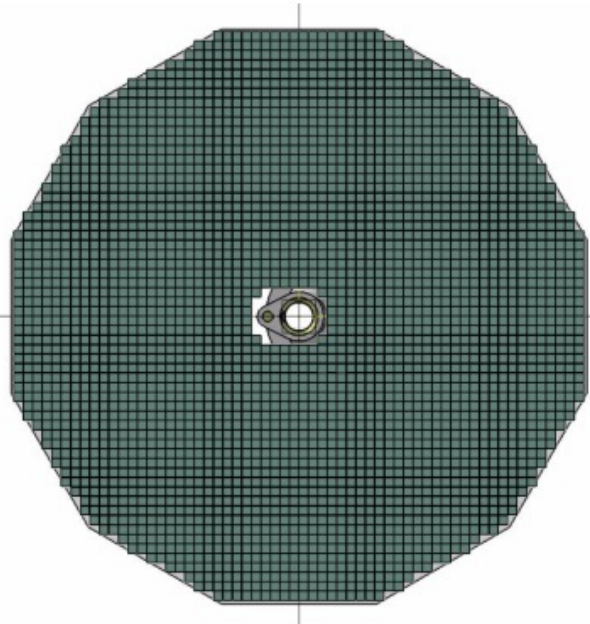

- 2x2x20 cm<sup>3</sup> PWO crystals
- 0.5-mm-thick C-fiber between crystals along 2 cm in the front & back; 0.5 mm of air elsewhere

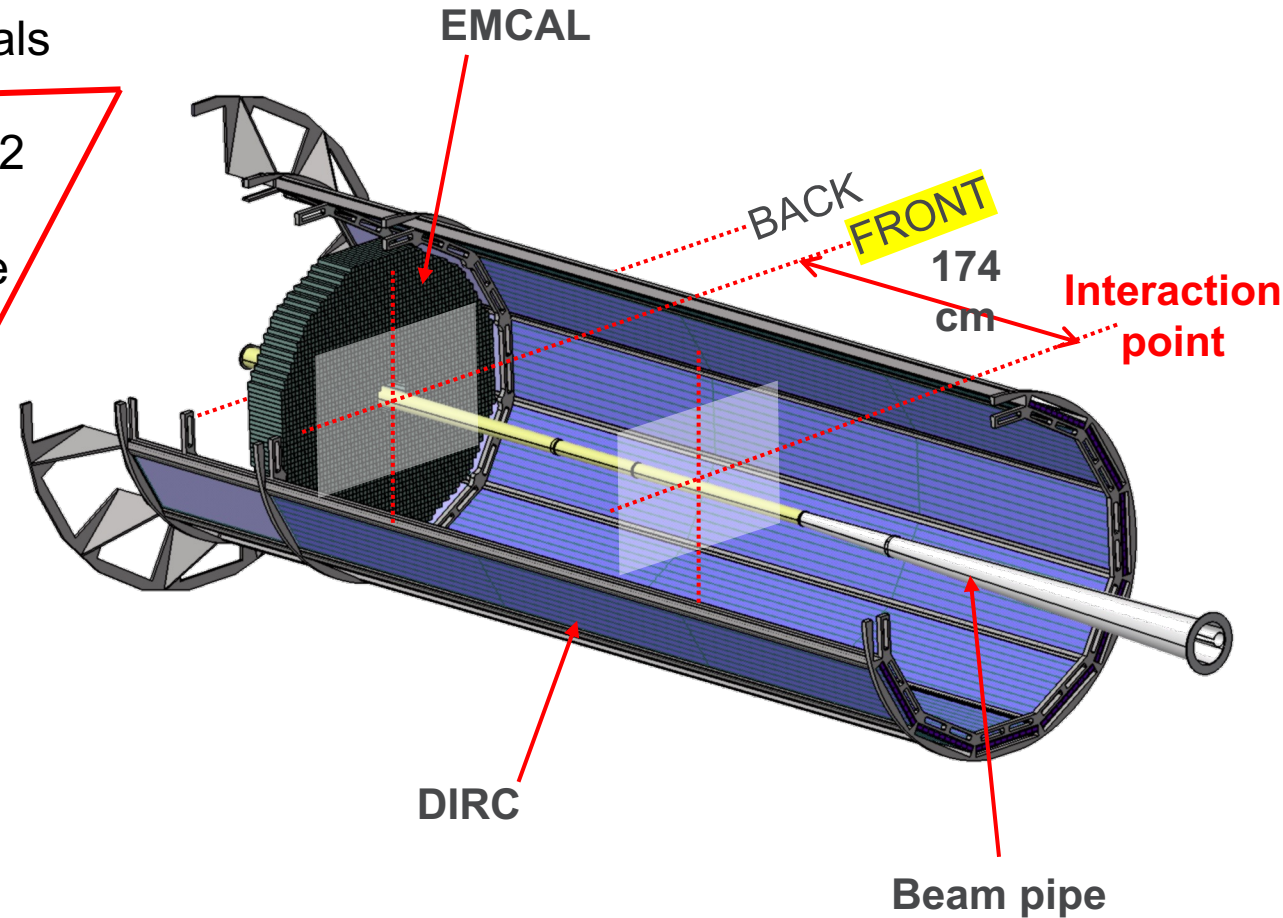
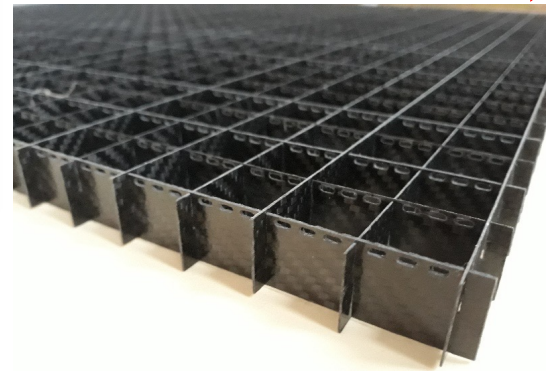

### Specifications:

PWO:	8,28g/cm <sup>3</sup>
Dimension:	20x20x200 mm
Mass:	0,662 Kg
Nb:	≈ 2850 crystals
Total mass:	≈ 1900 Kg
External diameter:	≈ 123 cm
Space max:	0,5 mm (carbon plate)

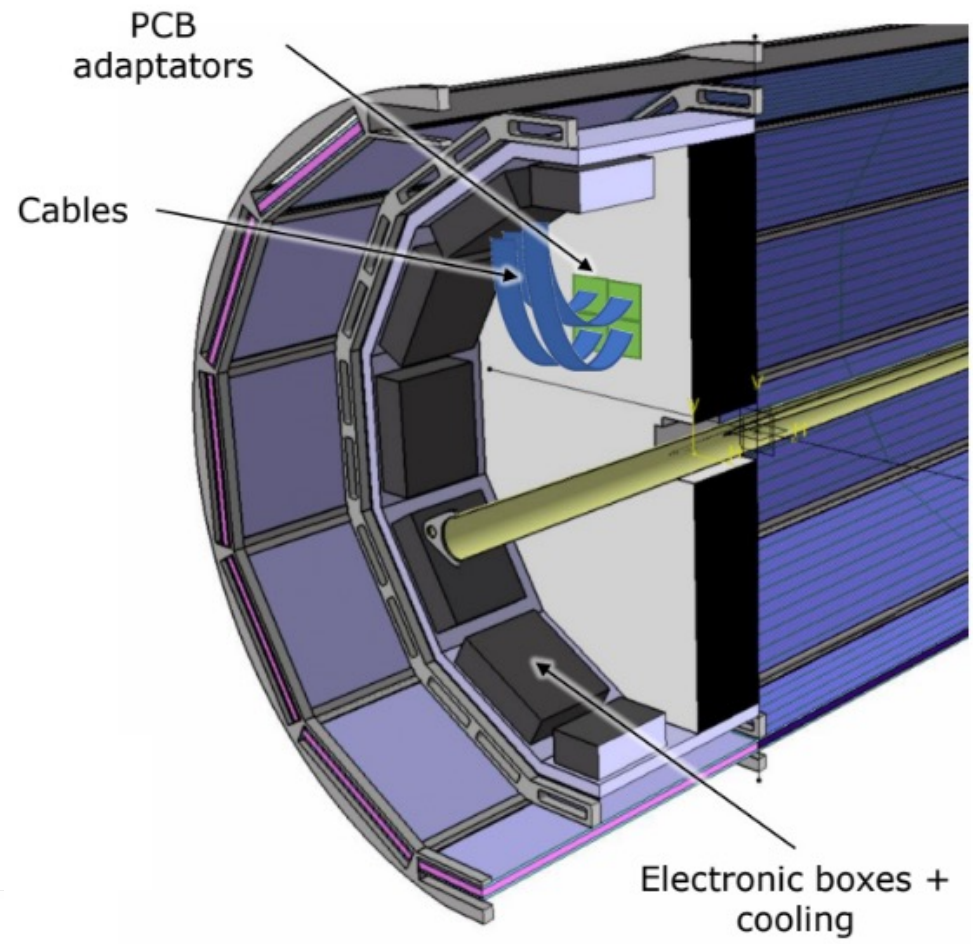
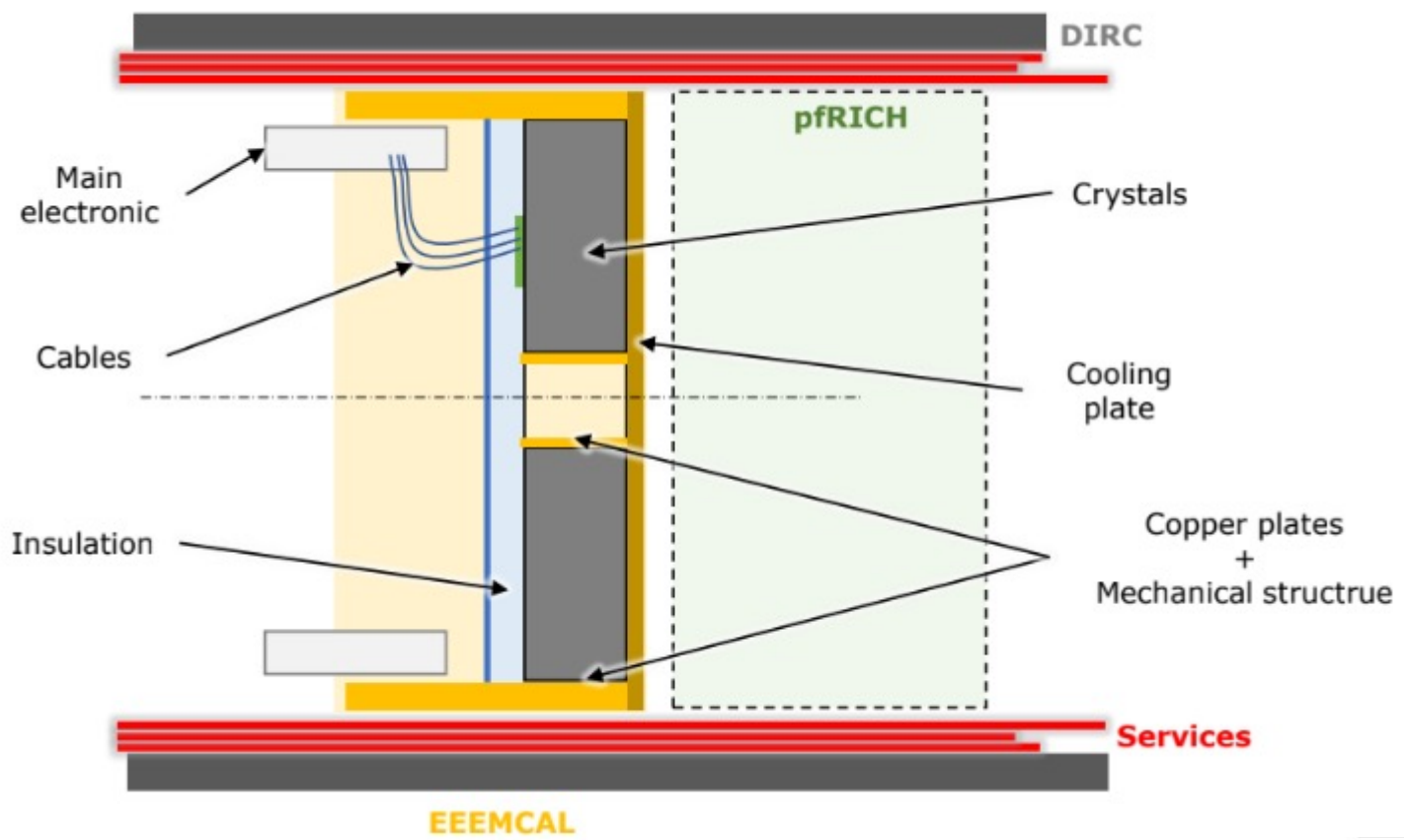



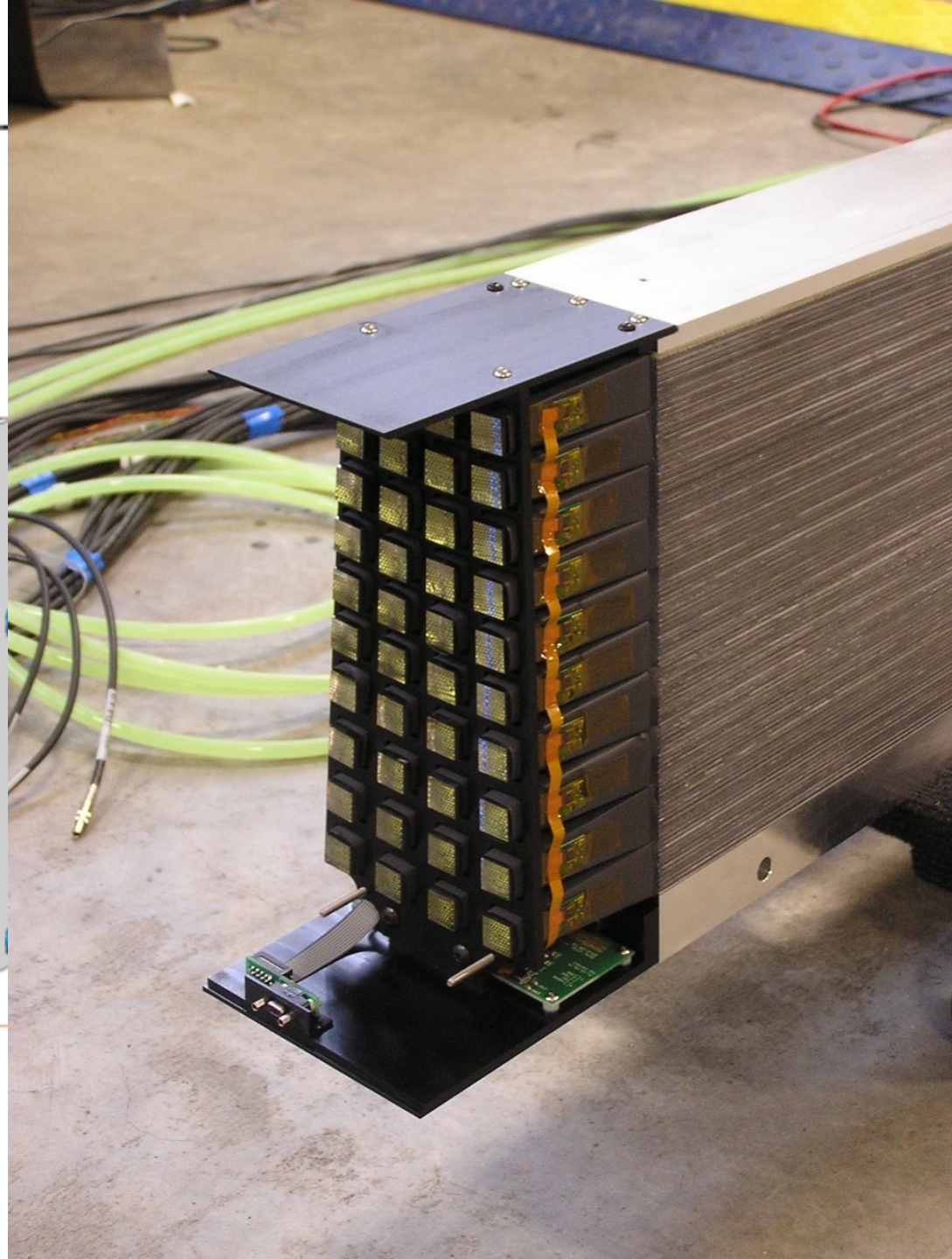
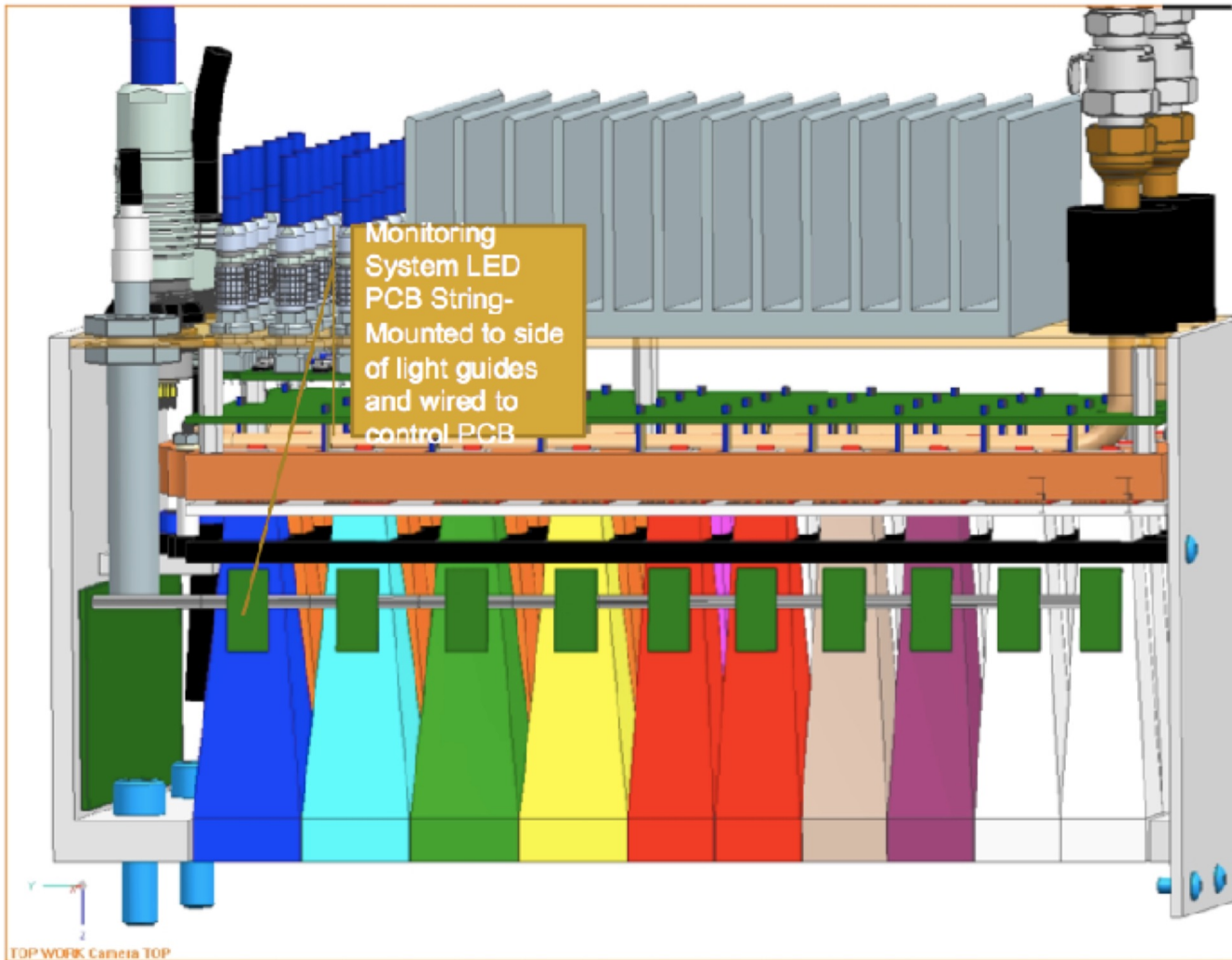

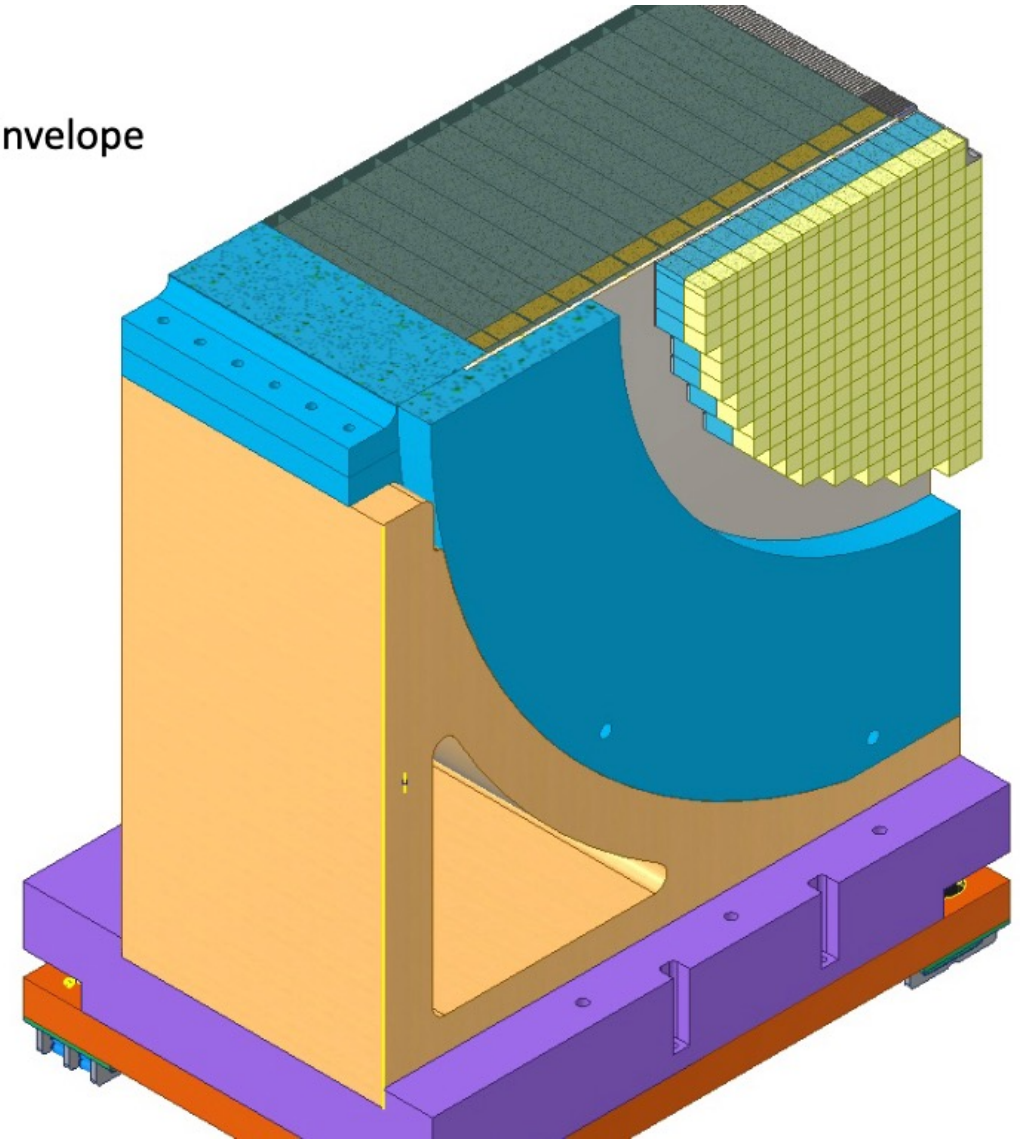
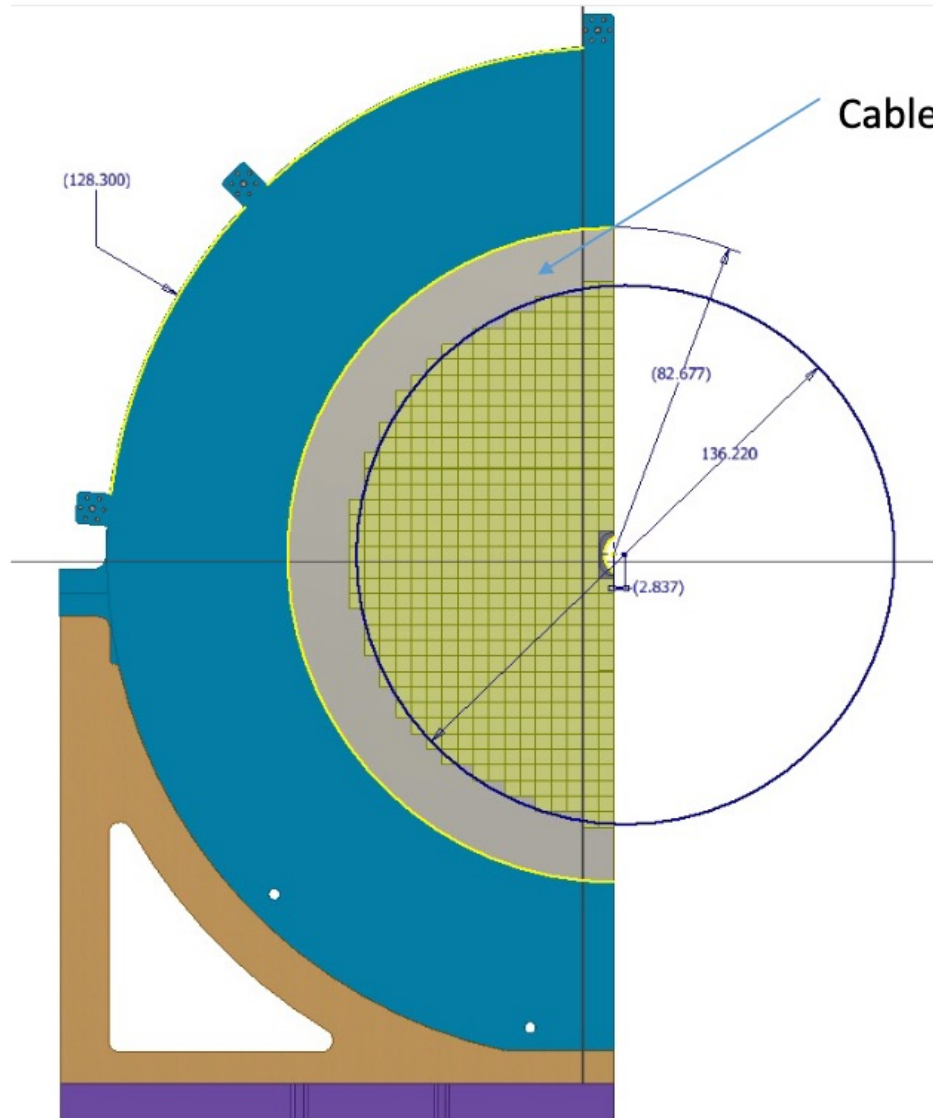



**Table 3.5:** EIC beam parameters for e-Au operation for different center-of-mass energies  $\sqrt{s}$ , with strong hadron cooling.

Species	Au ion	electron	Au ion	electron	Au ion	electron	Au ion	electron
Energy [GeV]	110	18	110	10	110	5	41	5
CM energy [GeV]	89.0		66.3		46.9		28.6	
Bunch intensity [ $10^{10}$ ]	0.08	6.2	0.05	17.2	0.05	17.2	0.036	17.2
No. of bunches	290		1160		1160		1160	
Beam current [A]	0.23	0.227	0.57	2.50	0.57	2.50	0.41	2.50
RMS norm. emit., h/v [ $\mu\text{m}$ ]	5.1/0.7	705/20	5.0/0.4	391/20	5.0/0.4	196/20	3.0/0.3	196/20
RMS emittance, h/v [nm]	43.2/5.8	20.0/0.6	42.3/3.0	20.0/1.0	42.3/3.0	20.0/2.0	68.1/5.7	20.0/2.0
$\beta^*$ , h/v [cm]]	91/4	196/41	91/4	193/12	91/4	193/6	90/4	307/11
IP RMS beam size, h/v [ $\mu\text{m}$ ]	198/15		196/11		197/11		248/15	
$K_x$	0.077		0.057		0.056		0.061	
RMS $\Delta\theta$ , h/v [ $\mu\text{rad}$ ]	218/379	101/37	216/274	102/92	215/275	102/185	275/377	81/136
BB parameter, h/v [ $10^{-3}$ ]	1/1	37/100	3/3	43/47	3/2	86/47	5/4	61/37
RMS long. emittance [ $10^{-3}$ , eV·s]	16		16		16		16	
RMS bunch length [cm]	7	0.9	7	0.7	7	0.7	11.6	0.7
RMS $\Delta p/p$ [ $10^{-4}$ ]	6.2	10.9	6.2	5.8	6.2	6.8	10	6.8
Max. space charge	0.007	neglig.	0.008	neglig.	0.008	neglig.	0.038	neglig.
Piwinski angle [rad]	4.4	1.1	4.5	1.2	4.5	1.5	5.8	1.2
Long. IBS time [h]	0.33		0.36		0.36		0.85	
Transv. IBS time [h]	0.81		0.89		0.89		0.16	
Hourglass factor $H$	0.85		0.85		0.85		0.71	
Luminosity [ $10^{33}\text{cm}^{-2}\text{s}^{-1}$ ]	0.52		4.76		4.77		1.67	



**Table 3.3:** EIC beam parameters for different center-of-mass energies  $\sqrt{s}$ , with strong hadron cooling. High divergence configuration.

Species	proton	electron	proton	electron	proton	electron	proton	electron	proton	electron
Energy [GeV]	275	18	275	10	100	10	100	5	41	5
CM energy [GeV]	140.7		104.9		63.2		44.7		28.6	
Bunch intensity [ $10^{10}$ ]	19.1	6.2	6.9	17.2	6.9	17.2	4.8	17.2	2.6	13.3
No. of bunches	290		1160		1160		1160		1160	
Beam current [A]	0.69	0.227	1	2.5	1	2.5	0.69	2.5	0.38	1.93
RMS norm. emit., h/v [ $\mu\text{m}$ ]	5.2/0.47	845/71	3.3/0.3	391/26	3.2/0.29	391/26	2.7/0.25	196/18	1.9/0.45	196/34
RMS emittance, h/v [nm]	18/1.6	24/2.0	11.3/1.0	20/1.3	30/2.7	20/1.3	26/2.3	20/1.8	44/10	20/3.5
$\beta^*$ , h/v [cm]]	80/7.1	59/5.7	80/7.2	45/5.6	63/5.7	96/12	61/5.5	78/7.1	90/7.1	196/21.0
IP RMS beam size, h/v [ $\mu\text{m}$ ]	119/11		95/8.5		138/12		125/11		198/27	
$K_x$	11.1		11.1		11.1		11.1		7.3	
RMS $\Delta\theta$ , h/v [ $\mu\text{rad}$ ]	150/150	202/187	119/119	211/152	220/220	145/105	206/206	160/160	220/380	101/129
BB parameter, h/v [ $10^{-3}$ ]	3/3	93/100	12/12	72/100	12/12	72/100	14/14	100/100	15/9	53/42
RMS long. emittance [ $10^{-3}$ , eV·s]	36		36		21		21		11	
RMS bunch length [cm]	6	0.9	6	0.7	7	0.7	7	0.7	7.5	0.7
RMS $\Delta p/p$ [ $10^{-4}$ ]	6.8	10.9	6.8	5.8	9.7	5.8	9.7	6.8	10.3	6.8
Max. space charge	0.007	neglig.	0.004	neglig.	0.026	neglig.	0.021	neglig.	0.05	neglig.
Piwinski angle [rad]	6.3	2.1	7.9	2.4	6.3	1.8	7.0	2.0	4.2	1.1
Long. IBS time [h]	2.0		2.9		2.5		3.1		3.8	
Transv. IBS time [h]	2.0		2		2.0/4.0		2.0/4.0		3.4/2.1	
Hourglass factor $H$	0.91		0.94		0.90		0.88		0.93	
Luminosity [ $10^{33}\text{cm}^{-2}\text{s}^{-1}$ ]	1.54		10.00		4.48		3.68		0.44	

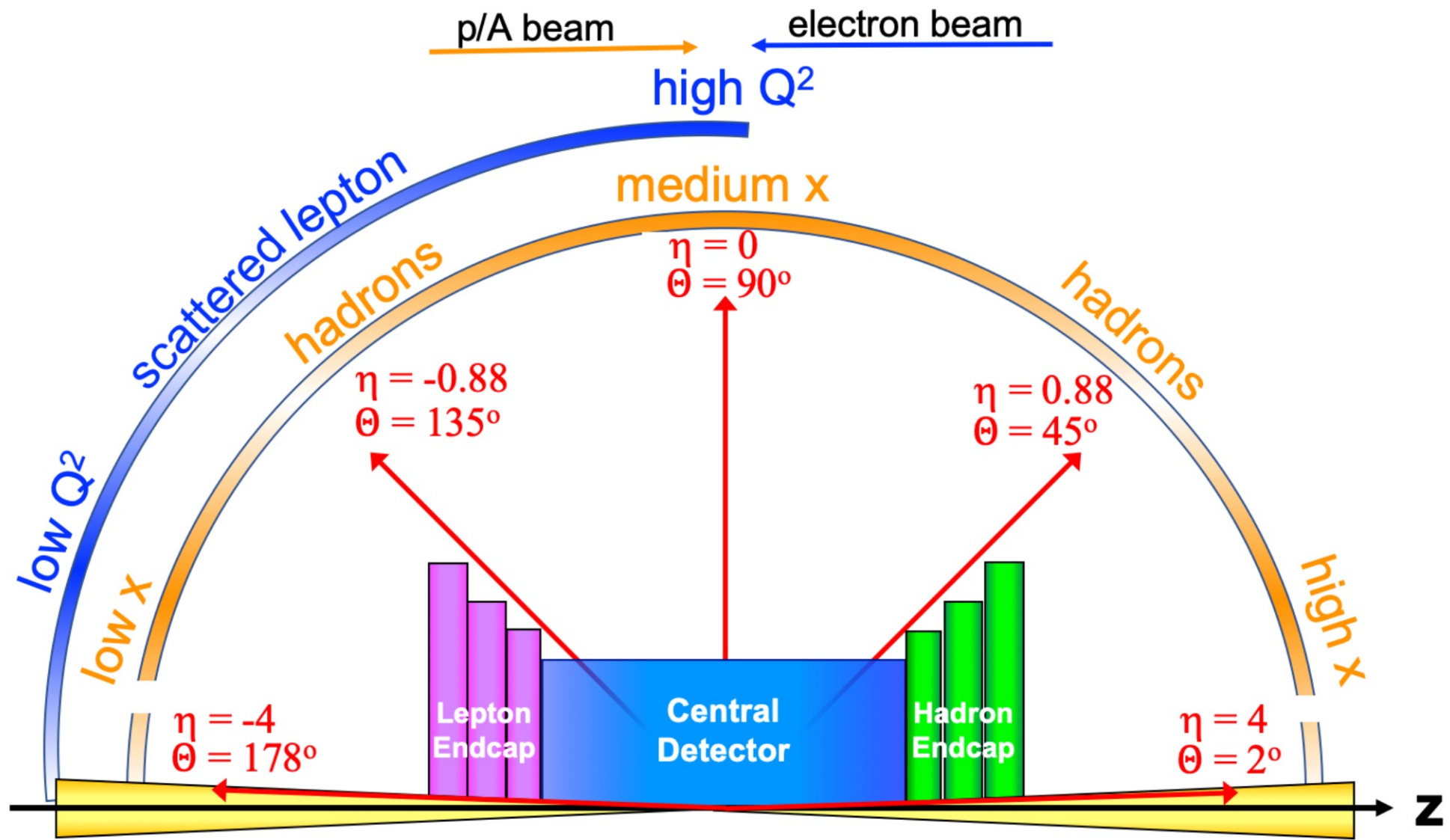

**Figure 8.1:** A schematic showing how hadrons and the scattered lepton for different  $x - Q^2$  are distributed over the detector rapidity coverage.

# Electron Identification

## Realistic ePIC simulation

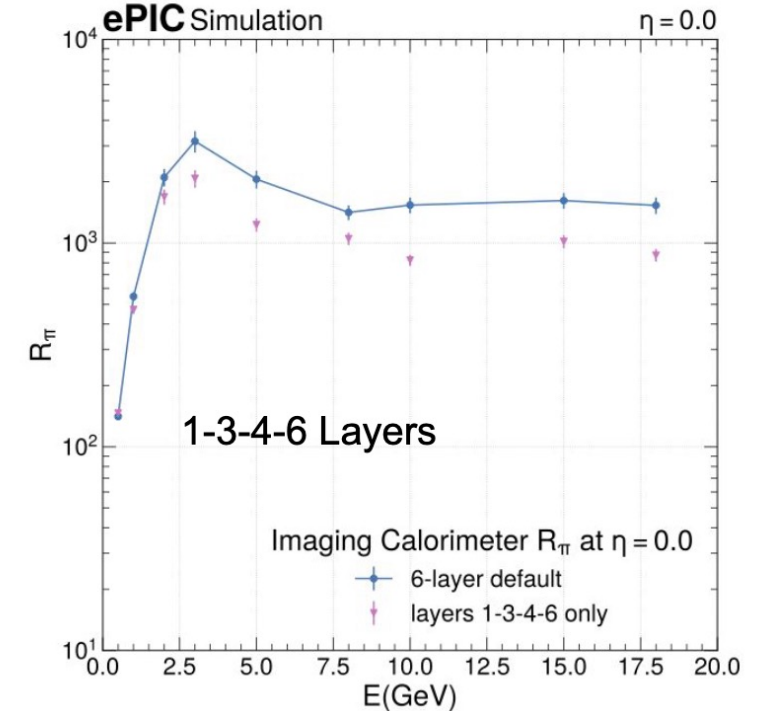
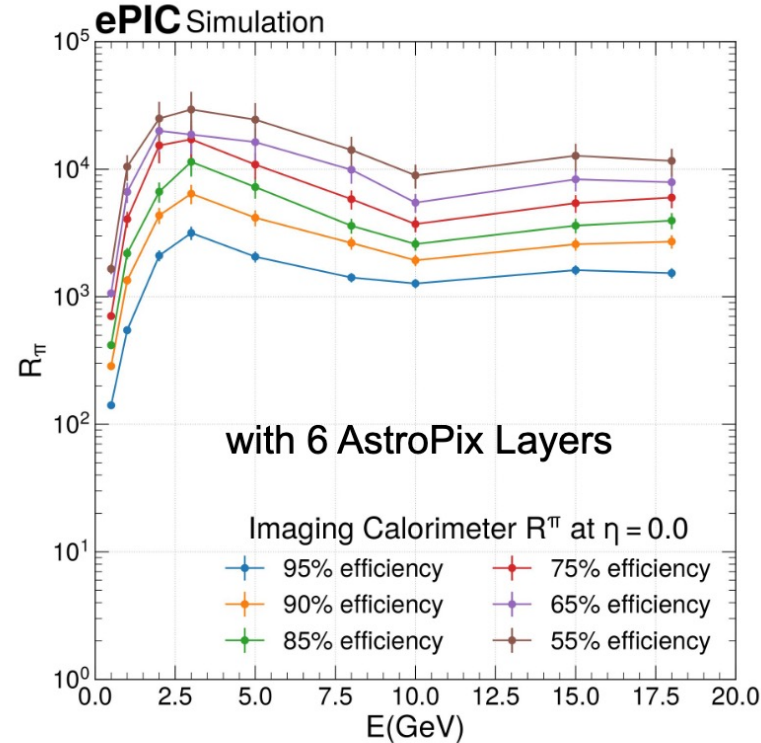
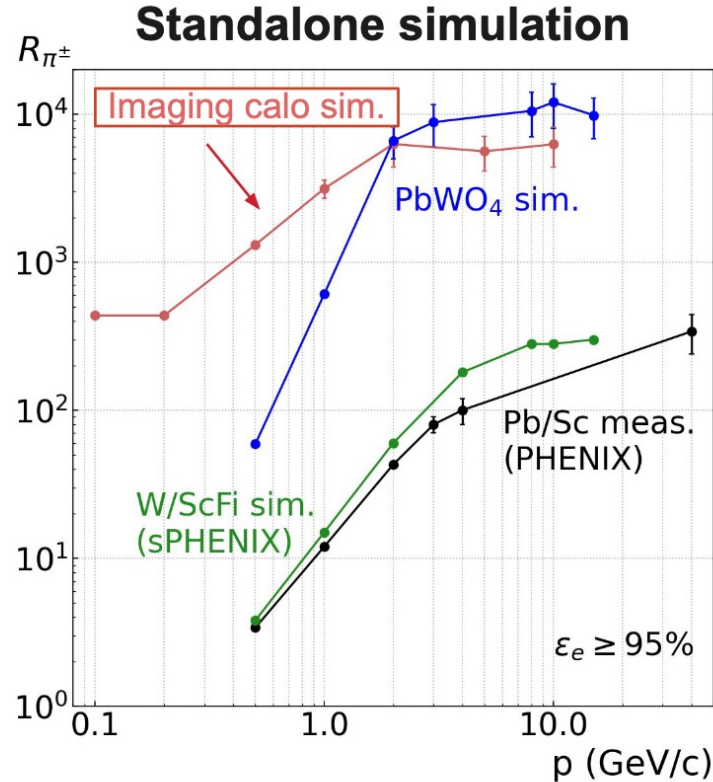

- **Goal:** Separation of electrons from background in Deep Inelastic Scattering (DIS) processes
- **Method:** **E/p cut (Pb/ScFi) + Neural Network** using **3D position and energy info** from imaging layers
- e- $\pi$  separation exceeds  $10^3$  in pion suppression at **95% efficiency** above 1 GeV in realistic



# Luminosity evolution of hadron-hadron and lepton-hadron colliders

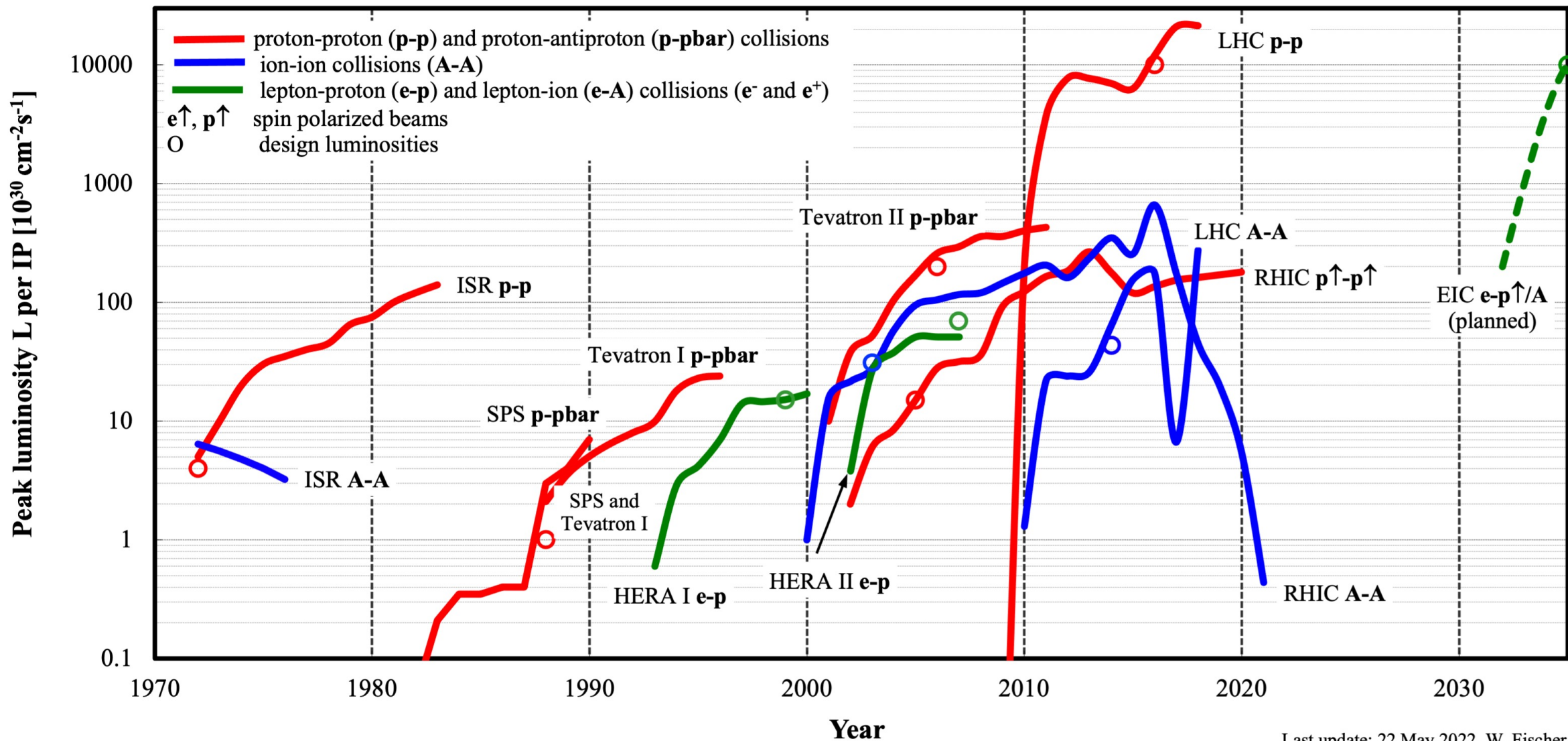

Last update: 22 May 2022, W. Fischer