

Transverse Single Spin Asymmetry of Electromagnetic Jets for Inclusive and Single Diffractive Processes at Forward Rapidity in $p^\uparrow + p$ Collisions at $\sqrt{s} = 200$ GeV at STAR

Xilin Liang, for the STAR Collaboration

University of California, Riverside

The XXXI International Workshop on Deep Inelastic Scattering and Related Subjects (DIS2024)
Grenoble, FRANCE
Apr. 10, 2024



Supported in part by

Transverse Single-Spin Asymmetry (TSSA, A_N)

- $A_N = \frac{\sigma_L - \sigma_R}{\sigma_L + \sigma_R}$
- pQCD predicts A_N is small:

$$A_N \sim \frac{m_q \alpha_s}{p_T}$$
- Large A_N at forward region is observed in proton-proton collisions

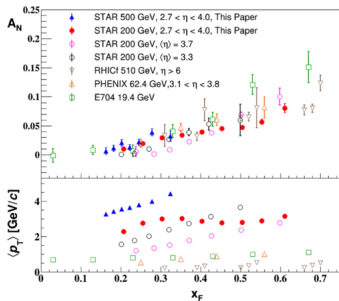
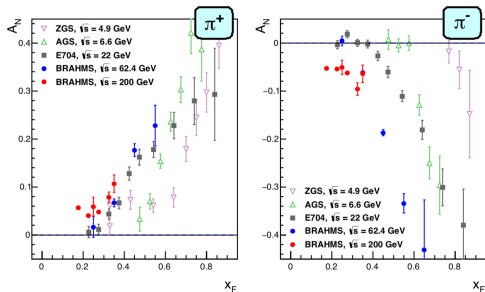
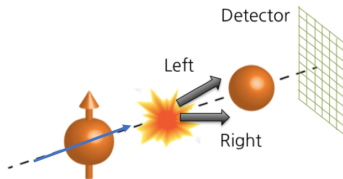

References:

- E.C. Aschenauer *et al.*, arXiv:1602.03922

- (STAR) J. Adam *et al.*, Phys. Rev. D 103, 092009 (2021)

Possible Mechanisms for TSSA

- **TMDs framework:**

Sivers effect : correlation between initial parton k_T and proton spin S_p

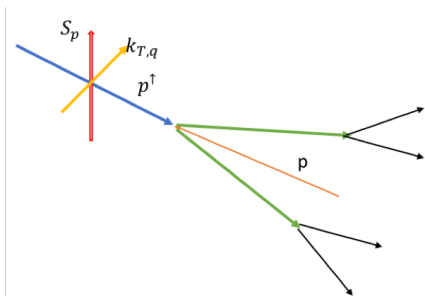

Ref: D. Sivers, Phys. Rev. D 41, 83 (1990)

Collins effect : correlation between fragmentation hadron k_T and its parent quark spin S_q

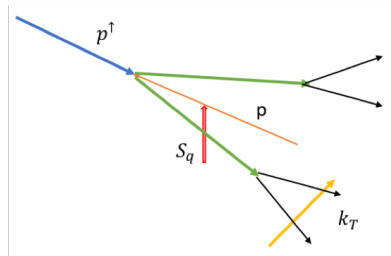

Ref: J. Collins, Nucl Phys B 396 (1993) 161

- **Twist-3:** Quark-gluon / gluon-gluon correlations and fragmentation functions.

Ref: J.W. Qiu and G. Sterman, Phys. Rev. Lett. 67 2264 (1991)

Indication of Large TSSA from Diffractive Process

- STAR inclusive A_N for forward π^0 in $p^\uparrow + p$ collisions : Isolated π^0 has larger A_N than non-isolated π^0
 - Isolated π^0 : No other nearby photons
- Indication: there might be non-trivial contributions to the large A_N from diffractive processes

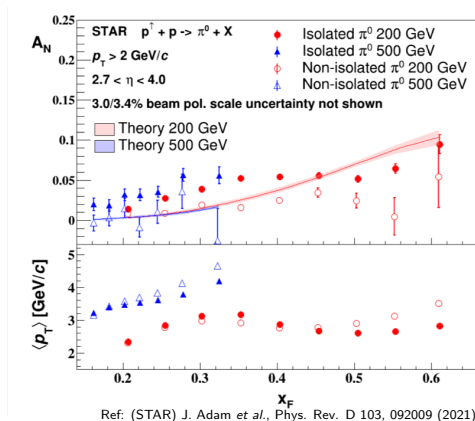

RHIC: Relativistic Heavy Ion Collider

- Located at Brookhaven National Laboratory (BNL) in US
- World's only polarized proton-proton collider with transverse and longitudinal polarization

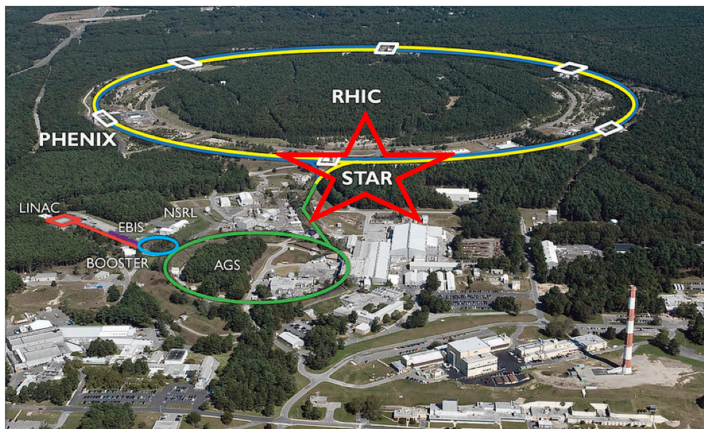

The STAR Experiment

- STAR sub-detectors used in measuring the A_N

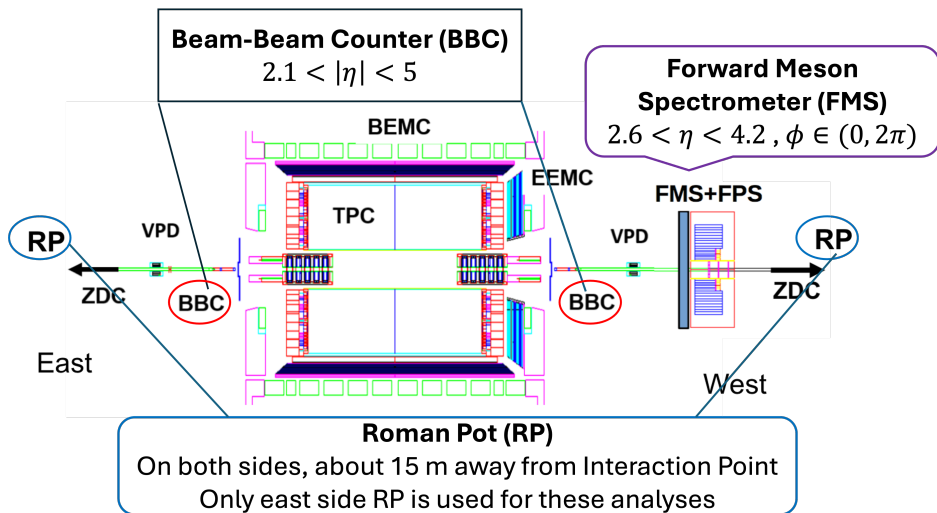

Electromagnetic Jets at FMS (FMS EM-jets)

- The Electromagnetic jets (EM-jets) are the jets reconstructed only using photons
- EM-jet reconstruction:
 - Anti- k_T , $R = 0.7$
 - Input: Photon candidate from FMS
- EM-jet correction:
 - p_T : corrected for Underlying Event using off-axis cone method
 - Energy: corrected to the particle level based on the MC simulation

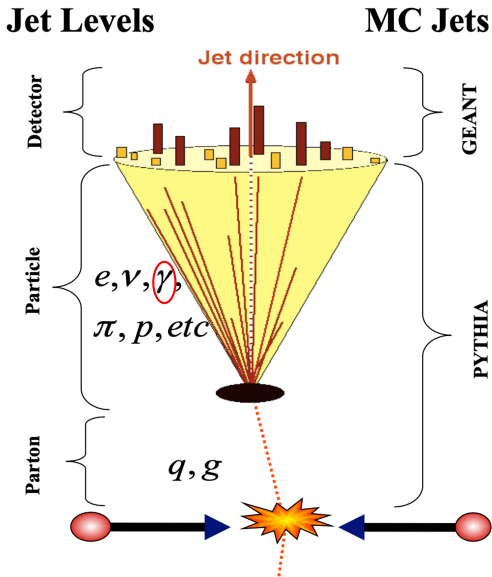

Inclusive EM-jet A_N at Forward Rapidity using FMS

Goals:

Characterize the EM-jet A_N as a function of EM-jet p_T , x_F and photon multiplicity to explore potential sources of large A_N

- Data set: Transversely polarized $p + p$ collisions at $\sqrt{s} = 200$ GeV collected in 2015 at STAR
 - Integrated luminosity: 52 pb^{-1}
 - Average polarization: 57%
- This data set is used for all analyses in this talk

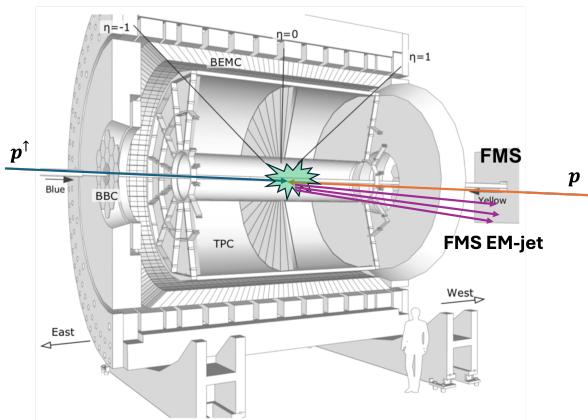

Multi-dimensional Inclusive EM-jet A_N at Forward Rapidity at 200 GeV

- The EM-jet A_N decreases with increasing photon multiplicity for $x_F > 0$
 - A_N is larger for the EM-jets consisting of 1 or 2 photons
 - A_N is smaller for EM-jets consisting of 3 or more photons
- A_N at $x_F < 0$ is consistent with 0

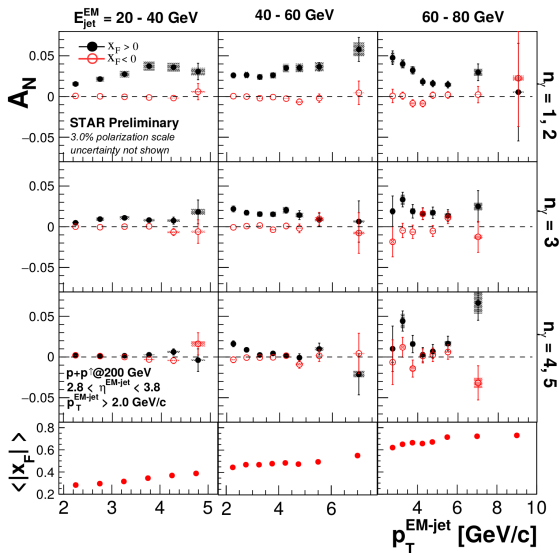

Inclusive EM-jet A_N at Forward Rapidity at 200 GeV

- A_N increases with x_F for all the cases of photon multiplicity
- EM-jets consisting of 1 or 2 photons have the strongest A_N
- Do they indicate the large A_N could come from diffractive processes?

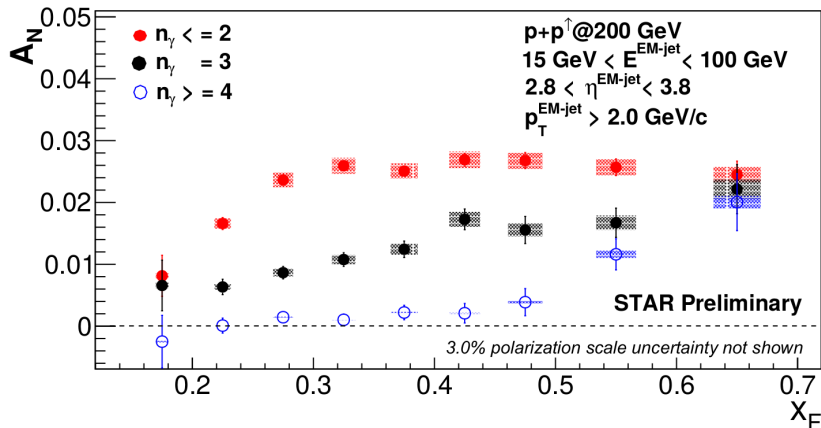

Single Diffractive EM-jet A_N at Forward Rapidity using FMS

- Single diffractive process:
 $p + p \rightarrow p + \text{EM-jet} + X$

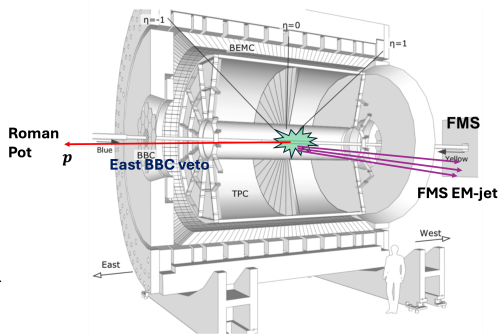
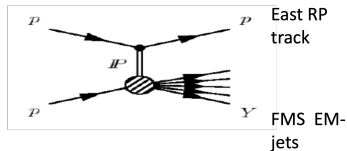

- Event selection:
 - 1 One EM-jet at FMS: Same FMS EM-jet reconstruction and correction
 - 2 One proton track detected by east side Roman Pot
 - proton momentum loss (ξ) < 0.15
 - 3 Veto on east side BBC ($-5 < \eta < -2.1$, Rapidity Gap!)

Photon Multiplicity Dependent Single Diffractive EM-jet

A_N

- The EM-jet A_N for $x_F > 0$ ($> 2\sigma$ significance of non-zero) is observed for the case of all photon multiplicity and 1 or 2 photon multiplicity
- The EM-jet with 1 or 2 photon multiplicity has stronger A_N
- The EM-jet with 3 or more photon multiplicity has A_N consistent with 0
- A_N at $x_F < 0$ is also consistent with 0

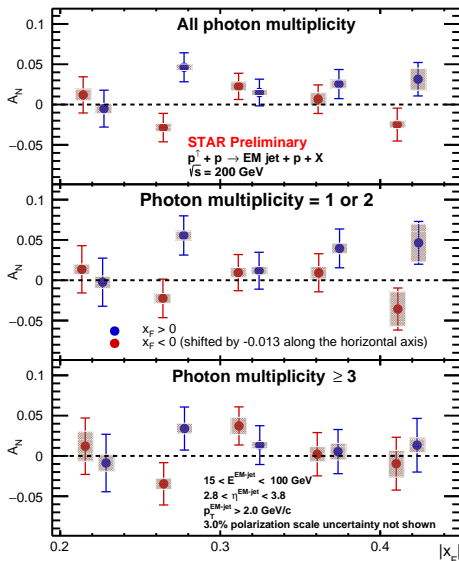

Rapidity Gap Event A_N at Forward Rapidity using FMS

Rapidity gap (RG) events

The Rapidity gap events require:

- EM-jet at FMS
- East side BBC veto (Rapidity gap)

Both are the same requirements as single diffractive process

No RP requirement for RG events

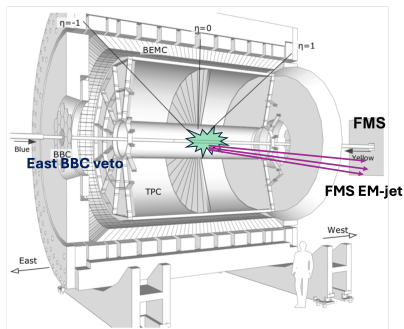

- Motivation:

- The single diffractive events with the proton tagged by east RP are small fraction of real single diffractive events due to limited RP acceptance
- At least 50% RG events are single diffractive events (precise fraction is under investigation)

Photon Multiplicity Dependent EM-jet A_N for Rapidity Gap Events

- The size of EM-jet A_N for rapidity gap events is similar to that for inclusive process
- The A_N for the EM-jet with 1 or 2 photon multiplicity is strongest

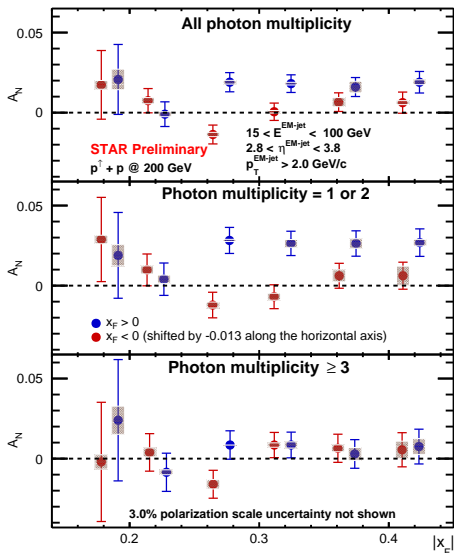

Will Single Diffractive Process Contribute to Large A_N in Inclusive Process?

- A_N for the three processes are the same within uncertainty
- Fraction of diffractive cross section in the total inclusive cross section at the forward region is about 20%. If the diffractive process have great contribution to large A_N in inclusive process, the huge A_N for diffractive process should be observed
- The single diffractive process can not provide evidence to have significant contribution to large A_N in inclusive process

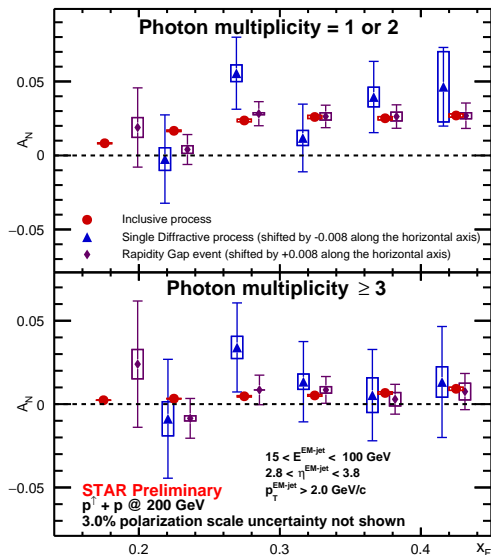

Conclusion

- ★ Multi-dimensional studies of A_N for inclusive EM-jets
 - The EM-jet A_N increases with decreasing photon multiplicity and increasing x_F , but with weak dependent on p_T
- ★ A_N for single diffractive EM-jets
 - A_N for the EM-jet with the case of EM-jet with all photon multiplicity, as well as 1 or 2 photon multiplicity are $> 2 \sigma$ significance to be non-zero
 - A_N for EM-jet with 3 or more photon multiplicity is consistent with zero
- ★ A_N for EM-jets from rapidity gap events
 - The A_N is similar to the inclusive EM-jet A_N
- ★ The single diffractive process can not provide evidence to have significant contribution to large A_N in inclusive process

Back up

Forward Meson Spectrometer (FMS)

- FMS can detect photons, neutral pions, and eta mesons in the forward direction
- $2.6 < \eta < 4.2$
- FMS consists of 1264 Lead-Glass cells with photomultiplier tubes (PMT) readout connected, separated into two regions
- Inner region (green) have smaller size cells than the outer region (red), which can provide better photon separation ability
- All cells have ~ 18 radiation length

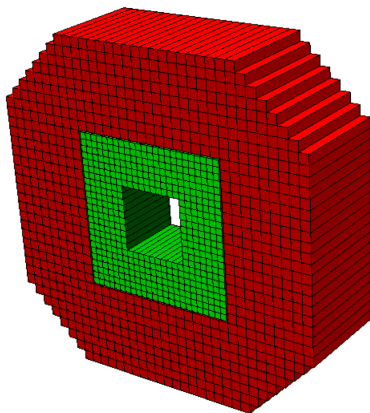

Roman Pot (RP)

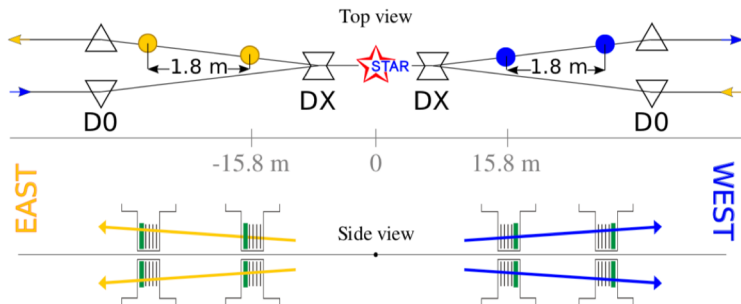

- Roman Pots (RP) are vessels which house the Silicon Strip Detector planes (SSDs). They are put close to the beam pipe
- RPs are able to detect and track slightly scattered protons close to beamline
- 2 sets of RP (inner and outer) on each side
- Each RP set contains a package above and below the beamline
- 4 SSDs per package (2 x-type and 2 y-type)

Underlying Events Correction and Energy Correction

- The EM-jet p_T values are corrected for contamination from Underlying Events (UE) with off-axis cone method
- The EM-jet energy is corrected to the particle level from MC simulation

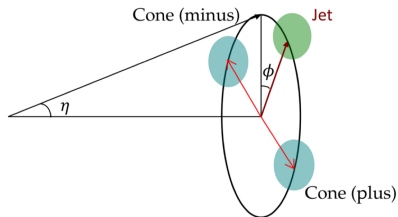

Phys Rev D **91** 112012 (2015), ALICE Collaboration

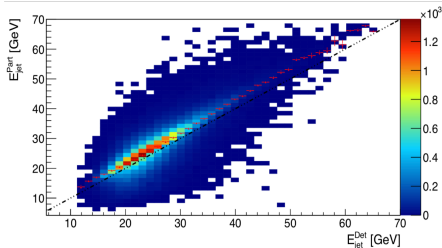

Figure: Detector EM-jet energy to particle level correction

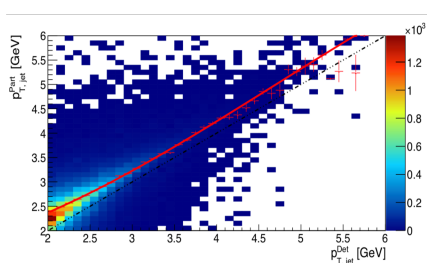

Figure: UE correction